

DIGITAL BONUS | OVER 15 PAGES OF BONUS MATERIAL!

www.verticalmag.com

Vertical

OCTOBER/NOVEMBER 2016

THE PULSE OF THE HELICOPTER INDUSTRY



MARENCO SWISSHELICOPTER

THE MYSTERY OF MAST BUMPING

ENGINE OEM SURVEY

1,000,000 hours & counting

Your complete guide to the Sikorsky S-92



THESE BLADES TURN MORE.

More Room. More Safety. That's why the H130 is a critical care transport star. With its large cabin, flat floor and flexible configuration options, the high-performance H130 allows better patient access, enhancing care. Safety features include a crash-resistant fuel system and energy-attenuating seats. Add lower direct maintenance costs and Airbus Helicopters' HCare warranty, and the H130 is an air ambulance that delivers.

Important to you. Essential to us.
www.airbushelicoptersinc.com



NO MATTER WHAT'S OVER THE HORIZON,
MILESTONE WILL BE THERE.



For any challenge that comes your way, take comfort in knowing that your helicopter leasing partner will be there for the long haul.

milestoneaviation.com



WHEN DEPENDABLE MEANS EVERYTHING



Each mission is unique, but all P&WC turboshaft engines have one thing in common: You can depend on them. Designed for outstanding performance, enhanced flying experience and competitive operating economics, the PW200 and PT6 engine families are the leaders in helicopter power. With innovative technology that respects the environment and a trusted support network that offers you peace of mind, you can focus on what matters most: **A MISSION ACCOMPLISHED**

DEPENDABLE ENGINES



WWW.PWC.CA



Pratt & Whitney Canada
A United Technologies Company

It's about your business



AW139

Finmeccanica is now Leonardo - inspired by the vision, curiosity and creativity of the great master inventor - designing the technology of tomorrow.

Challenging times require superior answers.

Leonardo Helicopters redefines mobility by setting new levels in luxury, comfort, performance and safety.

Maximise your time and be where it counts.

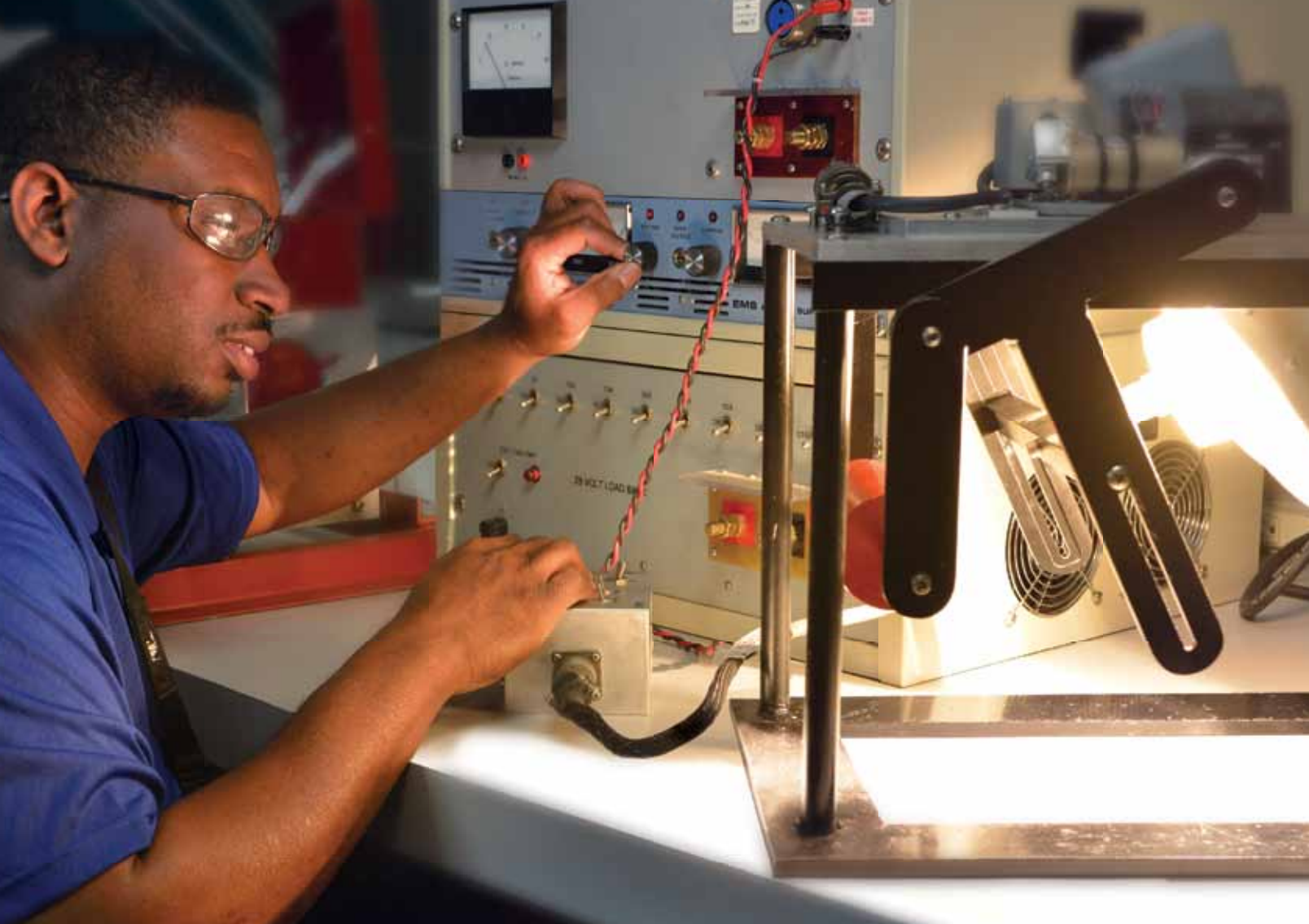

Atlanta, GA 404-768-9090

Brisbane, AU

Long Beach, CA

Peachtree City, GA

São Paulo, BR

Vancouver, BC

Starter Generators

Wheels & Brakes

Accessories

Avionics

Hydraulics

Instruments

**Let us shed some light
on hard to find parts.**

PHP
PRECISION HELIPARTS
A **PAG** Company

IS MRO

Inventory Supported
Maintenance - Repair - Overhaul

- 8 locations gives you just in time MRO support
- \$32.5 million dollar inventory / 75,000 line items
- Largest rotatable pool of accessories
- OEM Authorized stocking distributor
- AOG Support teams available 24/7

Hard to find parts are easy when you know where to look. Precision Heliparts (PHP) is your worldwide source for accessory, exchanges, overhauls and sales. Call today or visit us online at www.heliparts.com.

PHP is an Authorized Repair Center for **Luminator**

"Others sell parts, WE SELL SUPPORT"



058



064



078



092



126



138

Cover Story

092 | Versatile by Design

We explore the impact made by the Sikorsky S-92 as it reaches one million flight hours.

BY KENNETH I. SWARTZ

058 | Remotely Powered

How Bristow and Era are using UAVs to help service the oil-and-gas sector.

BY HOWARD SLUTSKEN

064 | Undetermined Reasons

Robinson helicopters continue to break up in flight, and we can't fully explain why.

BY ELAN HEAD

078 | Reaching for the SKYe

The story behind SKYe SH09 manufacturer Marengo Swiss helicopter.

BY OLIVER JOHNSON | PHOTOS BY EUGEN BÜRGLER

110 | 2016 Helicopter Engine Survey

We asked readers to tell us what helicopter engine manufacturers are doing right — and what they can do better.

BY ELAN HEAD | DATA ANALYSIS BY PMG INTELLIGENCE

126 | The Black Hawk's New Life

We check in with the first civilian operators of the Sikorsky UH-60 Black Hawk.

BY JEN BOYER

138 | The Mountain King

Celebrating 45 years of the Aerospaiale SA 315B Lama.

STORY & PHOTOS BY SKIP ROBINSON

In Every Issue

- 010** Focus On Safety
- 012** Focus On Training
- 014** Focus On Maintenance

- 016** Field Ops Photos
- 020** RotorBeat
- 056** Q & A

- 148** Vertical Rewind
- 156** Marketplace
- 174** There I Was...

Industry Experience. Financial Strength.

The **Waypoint** Advantage

Serving EMS operators
with state-of-the-art
medical helicopters

Safe & silent Fenestron® tail rotor

Most advanced human machine interface with innovative Airbus avionics suite

Full authority digital engine control (FADEC)

Two powerful Turbomeca Arriel 2E engines

High availability and cost-effective maintenance

Environmentally-friendly, with optimized fuel consumption

Extended mission capabilities with 4-axis autopilot

Rear clamshell doors enable easy and safe loading/unloading of patients

**Visit us at Helitech 2016 in
Amsterdam at Booth 10B30**

Airbus H145

 **Waypoint Leasing**

sales@waypointleasing.com • waypointleasing.com

cover



COVER A Sikorsky S-92 takes to the skies above the manufacturer's facility in Coatesville, Pennsylvania, ahead of its delivery to North Slope Borough, Alaska. The aircraft will be used primarily for search-and-rescue mission across the Borough, which is the northernmost municipality in the United States, and covers 94,796 square miles.

SKIP ROBINSON PHOTO

what's online? verticalmag.com

Subscribe to Vertical News
verticalmag.com/subscription



Read the Magazine Online
verticalmag.com/digital



Follow us on Twitter
Follow @verticalmag



Like us on Facebook
facebook.com/verticalmag



Follow us on Instagram
Follow @verticalmag



Watch videos on Vimeo
vimeo.com/mhmma



Shop Vertical Merch
shopcanada.mhmpub.com
shopinternational.mhmpub.com



Have a great photo to share? We want to see it!

Congratulations to one of August's Facebook photo contest winners, **Francisco Canet!**

If you have a helicopter-themed photo you'd like to share, post it to our Facebook page at www.facebook.com/verticalmag, or tweet it to us @verticalmag, or share it on Instagram using the hashtag #verticalmag. In addition to receiving prizes, our weekly winners have their photos featured on our home page and in *Vertical Daily News*, our daily email newsletter.



Vertical In Canada: 500 Trillium Dr., Unit 23, Kitchener, ON N2R 1E5
In the United States: 701 S. Main Street, Fall River, WI 53932

THE TEAM

GROUP PUBLISHER Mike Reyno ■ mike@mhmpub.com
GROUP PUBLISHER Linda Reyno ■ linda@mhmpub.com
ASSOCIATE PUBLISHER Derek Kast ■ derek@mhmpub.com
MANAGING EDITOR Oliver Johnson ■ oliver@mhmpub.com
SPECIAL PROJECTS EDITOR Elan Head ■ elan@mhmpub.com
ASSISTANT EDITOR Ben Forrest ■ ben@mhmpub.com
JR. EDITOR Sarah Grandy ■ sarah@mhmpub.com

SALES & MARKETING DIRECTOR Tim Muise ■ tim@mhmpub.com
MARKETPLACE SALES MANAGER Carla McKay ■ carla@mhmpub.com
CIRCULATION MANAGER/MARKETPLACE SALES Leanne Willis ■ leanne@mhmpub.com
PRODUCTION MANAGER Jen Colven ■ jen@mhmpub.com
GRAPHIC DESIGNER Kaytlyn Wismayer ■ kaytlyn@mhmpub.com
SR. WEBMASTER Christopher Zimmermann ■ christopher@mhmpub.com
WEBMASTER Shawn Pieters ■ shawnp@mhmpub.com

CONTRIBUTING EDITORS:

Jen Boyer, John Carinha, Thierry Dubois, Geoff Goodyear, Mike Muench, Bob Petite, Skip Robinson, Andy Roe, Howard Slutsken, Kenneth I. Swartz

CONTRIBUTING PHOTOGRAPHERS:

Ahmed Al Hader, Isaac Brekken, Eugen Bürgler, Ted Carlson, Sheldon Cohen, Fernando Dominguez, YoHan Han, Caterina Jahnke, Ammy Jorgenson, Dan Megna, Matthew Melsness, Jay Miller, Heath Moffatt, Douglas Noblet, Anthony Pecchi, Mike Reyno, Skip Robinson, Kenneth I. Swartz, Ricardo Zenner

PUBLISHED AND PRODUCED BY: MHM Publishing Inc. **SUBSCRIPTION INQUIRIES CALL TOLL-FREE:** 866.834.1114

Vertical Magazine (ISSN 1703-8812) is published six times per year (Dec/Jan, Feb/Mar, Apr/May, Jun/Jul, Aug/Sept, Oct/Nov) by MHM Publishing Inc., paid at Fall River, WI. Postmaster please send address changes to: *Vertical Magazine*, PO Box 8, Fall River, WI, 53932.

All material published remains the copyright of MHM Publishing. No part of this publication in whole or in part may be reproduced without written permission from the publisher. Editorial published in *Vertical Magazine* does not necessarily reflect the views of the publisher. Information contained within *Vertical Magazine* is believed to be accurate, but the publisher assumes no responsibility for errors. *Vertical* will consider unsolicited, quality stories and pictures, but the publisher cannot assume any responsibility for the safe return of submitted material.

© Copyright 2016 MHM Publishing Inc.
International Serial Number ISSN 1703-8812

Canadian Publication Mail Agreement Number: 40741549 ■ Postmaster: If undeliverable, return mailing label only. ■ Printed in U.S.A.

Vertical is proud to be a member of



by Geoff Goodyear



To Land or Not to Land?

There are some pretty interesting debates going on within our industry these days. In Canada, regulatory issues such as flight and duty times and H1 helipad standards are made all the more acute given the uncertain times the industry faces.

As some of you may be aware, the performance standards for heliports labeled as H1 precludes many of today's aircraft from using them, and more and more hospital helipads are restricted to H1 traffic due to surrounding buildings or, as is often the case, encroachment of hospital parking along traditional approach/departure routes.

Many of us have been flying for a while without having to consider such issues during medevacs. Here in Newfoundland and Labrador, many medevacs I flew were conducted to very remote communities, and the biggest issue I had to face was making sure the cottage hospital had enough warning to evacuate the parking lot so I could land in it. Flying over the parked cars was never an issue!

There have been lots of interesting air ambulance events here over the years. One involved one of our pilots who was tasked with getting to the south coast community of Burgeo to retrieve a poor soul who had his "tongue cut off!" Now, you can image that given such a severe injury our pilot spared no effort and braved the most distasteful conditions to get to the hospital pad (in a province known for fog, Burgeo can be in a league of its own for reduced visibility).

He shut down the aircraft and ran to the hospital door with a stretcher, passing by a gentleman who had his hand bandaged.

"Are you here to take me back to Corner Brook?" asked the gentleman.

"Sorry skipper — I can't stop to talk. There is a patient in here with his tongue cut off!" replied the pilot. As the pilot continued to the hospital door he heard the gentleman exclaim: "Lard dy'in! I don't know how many times I have to tell them.... It is my tum [a.k.a. thumb] that's cut off.... Not me tongue!"

This is but one of a thousand air ambulance anecdotes from the hinterland. I have many of my own as a pilot, and one memorable recent event as a patient. I have recounted this story before from a perspective of being distracted, but I can't help but recall some of the evacuation details as we embark on the H1 standards debate.

I fell into the only manhole within a 300-kilometer radius while doing a DI on my aircraft. It was a traumatic event that culminated with my left foot pointing in the opposite direction to my right. I had broken my leg... and it hurt! But my adventure was just beginning, as an injury such as mine would normally be evacuated by, you guessed it, the helicopter. And the helicopter was now without a pilot. My evacuation involved a farcical remake of *Planes, Trains and Automobiles*. First, we had to wait approximately six hours for a Twin Otter to get to a nearby airstrip. I was then laid on

a stretcher and put into an ATV trailer and transported to a floating dock. From there, I was moved up to the stern of a longliner to be taken across Saglek Bay close to shore by the airstrip. Then I was lifted from the stern of the longliner to a Zodiac which most certainly exceeded heave limits in the swell. Some well-meaning attendant suggested strapping me into the stretcher but I declined the option. I still had three out of four appendages working and wanted a fighting chance if dropped overboard! We then ran the Zodiac up on the beach, where I was transferred to the back of a pick up for a drive along an unserviced dirt road to meet the Twin Otter. Then the flight back, assessment, transfer to St. John's, surgery, and so on. The medevac took 17 hours, and I ended up in St. John's with one sock, my skivvies, and a T-shirt. Everything else I owned in the world was spread evenly between Saglek and St. John's. Your perspective as a patient tends to be a little different than that of the crew.

Most air ambulance operations are far more efficient and less daunting than this one, but as we close down more hospital helipads to all but the most recent and powerful multi-engine helicopters, I can't help but wonder if we should revisit the concept of risk assessment. Risk is prioritized based on probability versus consequence. If the medical authority on board your aircraft determines that not landing at the hospital pad will result in the patient's death, then would the risk of a power loss while approaching over a parking lot for a very short period be acceptable?

It's a rhetorical question on my part, as I am not in a position of authority to affect the outcome. But I hope those engaged in the debate consider all the stakeholders including patients — some with broken limbs!

“ Here in Newfoundland and Labrador, many medevacs I flew were conducted to very remote communities, and the biggest issue I had to face was making sure the cottage hospital had enough warning to evacuate the parking lot so I could land in it. Flying over the parked cars was never an issue!





THANKS A MILLION.

S-92[®] HELICOPTERS ACHIEVE 1,000,000 FLIGHT HOURS.

AT LOCKHEED MARTIN,
WE'RE ENGINEERING A BETTER TOMORROW.

To our loyal customers and operators: Thank you for entrusting Sikorsky to build, deliver and service your aircraft. We are proud to provide the award-winning S-92 helicopter for your needs, and we are committed to keeping your aircraft flying, adding to the next million hours of safe, reliable flight.

Learn more at lockheedmartin.com/sikorsky or call 1 800 WINGED S.

by Andy Roe



Autonomous Flight Control & Human Factors

The horse and similar animals first helped us to move more efficiently across the ground. Soon, more sophisticated human-controlled transportation was being developed on the ground, in the air, and on and under water. Then came the onslaught of computer technology and the rise of machines, both of which have evolved rapidly in recent years — and now we seem obsessed with self-driving vehicles. But does autonomous control match human control?

Vancouver, where I live, operates the longest automated transit system in North America and no one seems bothered that no one is at the controls. The ride share companies are gearing up for autonomous taxi service, and the cars we drive are getting more and more self-driving features to take care of tasks such as car-to-car separation, lane control, and parking.

Most of us have an inkling of the complexity of the latest technological advancements. Mega data gathering has given rise to advanced pattern recognition, computational machine learning, neural networks and ever-evolving unsupervised learning. The possibility of true artificial intelligence is becoming science fact rather than fiction.

An autonomous helicopter recently demonstrated the ability to drop water on a fire at night in instrument meteorological conditions, which makes human control seem fragile in comparison. Machines, not suffering from human error, also make us look bad when it comes to safety, and if we are going to continue to fly helicopters ourselves, intense and thorough training is the only way to reduce accidents caused by human factors.

Human factors is a slightly ambiguous term for the study of the interaction between humans and the other elements of a system, in this case the pilot interacting with the helicopter controls. Human

error has been the primary contributor to more than half of all airplane hull-loss accidents. Gathering information about human inabilities and limitations and intensifying training practices to try and minimize human error is more important than ever, since technological advancement won't abate anytime soon.

Most flight schools cover the topic of human factors as one of many lectures, when in fact it would be far better to expand ground training to include more discussion on how to make human interaction with flight control safer. College aviation diploma programs devote much more time to human factors because they have a much longer diploma course duration than a conventional flight school.

In our society, there has always been an acceptance that “accidents can happen” and “that’s too bad, but it wasn’t my fault.” In one family I know, the daughter wrote off her father’s new car in a corner she couldn’t negotiate properly — and blamed it on the car. These attitudes when applied to aviation will not lessen the accident rate — they simply seek to justify it. Absurd! If we can nail down the human traits that often lead to improper control, poor judgment or irrational decision making, and take measured steps to try and improve on these faults, we could end up with a pilot who is much safer in a helicopter or in any other vehicle. This is not a new concept, but could be intensified even more than before because of the evolution of machines.

Behaviorism is the study of human conditioning rather than applied thoughts or feelings. If someone is conditioned during youth to be ambivalent or to apportion blame frivolously, this will have a less than desirable impact with airborne decision making. This type of behaviorism can be altered with training. Unfortunately, most human factors training serves to bolster

positive traits rather than to identify behavioral inadequacies that with change could heighten overall safety in the air.

At present, pilots are still positioned behind the cyclic, but man’s intrigue with advanced autonomous control is rapidly gaining ground. As a prospective pilot wanting to make a living flying helicopters you are challenged more than ever by industry and environmental trends and autonomous control. Human pilots must be trained to fly as efficiently and safely as possible to lessen the gap between machine perfection and human inadequacy.

Most of us are aware these days that passenger airliners fly themselves and the pilots are often at the controls for just a few minutes during the takeoff and landing. Most of us are not aware that when things go wrong in flight, even though the computers have the ability to find solutions to problems, they are programmed to relinquish control to the pilots. Every crash then is caused by human error, which our legal system can handle. While computers would be better able to analyze an emergency and take an appropriate course of action, our legal process is not yet capable of apportioning blame for an accident on a machine. Humans are the scapegoat for now.

As long as humans are going to be piloting helicopters, the need for improved human factors training is of vital importance. Imagine flying alongside another helicopter — but this one pilotless. Not too stressful a task controlling a fully functioning helicopter in flight. But what if both machines became incapacitated? The autonomous one would immediately revert to the correct emergency procedure, descend, and probably land safely. Would you be able to do the same? That is the competition pilots are now faced with. ❖

MD™ 530F

HIGH ALTITUDE, HOT-DAY WORKHORSE.

The MD 530F is engineered to meet your requirements for hot-day, high-altitude operation. Equipped with the 650 shp Rolls-Royce 250-C30 engine, the MD 530F operates more effectively in hot, high environments than other helicopters in its class. It offers the performance you need... at a lower cost of ownership.



MD HELICOPTERS™

MADE IN AMERICA

[f](#) [t](#) [in](#) [ig](#) | MDHELICOPTERS.COM

by John Carinha



The Magic of Maintenance

I've always been a lover of magic. The idea of not believing what I'm seeing and figuring out the "how" and "why" has always fascinated me.

The beauty of working in electronics is that much of what happens functionally is not actually visible. We connect a wire and expect that electrons will flow happily and readily and give life to whatever component or part they are attached to. When it comes to electro-mechanical parts, there is usually a moving component that gives us the visual acknowledgement that such wiring is indeed providing a function.

On a recent project, my team had worked together with another MRO company to refurbish and rebuild an MD 500F helicopter. The overhaul of components and wiring was so extensive that the aircraft was as near new as it could get. After the usual completion checks, ground runs, and flight tests, the aircraft was delivered to the end user.

What followed that delivery was almost two months of continuous call backs to service lateral and/or longitudinal trim actuators — neither of which are inexpensive — that were oddly failing at a rate of one to two per week of operation. Eyebrows were raised, patience tested, and wallets emptied. This was a very expensive problem, and one that defied all logic.

The mechanical flight control rigging was checked and checked again. Electrically, we tested the trim actuator motor operation and wiring and could not find anything

remotely wrong. As times turned desperate, the only logical direction to take was to troubleshoot from the component backwards. In other words, have the damaged actuators assessed for what actually failed and list the probable causes. What became clear was that the electrical motors themselves were for the most part still operational, but the internal gear was found to be in various stages of disrepair, rendering the actuator unserviceable. This discovery along with the high rate of failure begged only one question: what flight profiles were they being subject to such that they could or would foreseeably fail?

No MD 500 pilot I spoke to had any rationale for it. "Never in my 20,000-plus hours of flying have I seen..." was usually how their response to me began. But after extensive discussions with the client's flight crew, the helicopter manufacturer, and an aftermarket OEM of an equivalent PMA part, the cause and effect aspects became clear.

A requirement of the client's air operator's certificate was that all pilots were trained on type and had extensive training with runaway trim scenarios. The outcome of this exercise is that the pilot is able to maintain level and controlled flight when an offset force or external pressure is simulated and felt at the cyclic stick. One way to simulate this is to trim the lateral and or longitudinal actuators out of trim and have the pilot fly circuits demonstrating controlled flight.

What was transpiring during training was a far more aggressive approach to this exercise, which placed these actuators under extensive repetitive load and high duty cycles. The pilot was running the actuator hard over in one direction, pulling the circuit breaker to the system, countering the force by hand, and then resetting the circuit breaker once the exercise was complete. When the system was reset, the actuator was exposed to a large built-up counter force, much like a rubber band. The recoil on the actuator was such that after continued use, something had to give.

The aircraft OEM confirmed that this only required very minimal opposite trim movement, just enough for the pilot to sense the load on the cyclic and counter it safely. They recommended against the described procedure, and added that a rotor r.p.m. of 103 percent should always be established to ensure the main rotor blades are off their droop stops. The pilot(s) under test with our client had previous 500D and E experience, but the F model's longer blades added even more load to the cyclic system, putting an even greater stress on the actuators.

There are times when helicopters and all their intricate parts try their best to pull a David Copperfield. But much like an onion, every problem we encounter has layers. There are times the resolve lies less in what was wrong, but rather, why. Sometimes tools can stay in the toolbox. Occasionally, solving a mechanical riddle is more about peeling back the layers and exposing facts, history, and procedure — coupled with asking the right people the right questions. Something that experience has convinced us to be normal can, in fact, be just an illusion.

“ There are times when helicopters and all their intricate parts try their best to pull a David Copperfield. But much like an onion, every problem we encounter has layers.





Your Go-To Support Solution

INSTRUMENTS + AVIONICS + ACCESSORIES

STARTER GENERATOR MRO SPECIALISTS

817-481-8205 TX
337-364-0789 LA
www.mascoservice.com



An MD 530F operated by The 7 Group for the Kurdish Police in Erbil maintains a careful balance in this beautiful shot by **Gabriel Fest**.





Billy Bezeau-Tremblay captured this striking photo of an Expedition Helicopters Airbus AS350 conducting spray work near Nipigon, Ontario.

A Leonardo Helicopters AW139 operated by the Irish Air Corps arrives at University Hospital Galway, Ireland.
David McGrath Photo





A modified Bell 205A-1 at Agua Dulce Airpark while assigned to the Sand Fire in Southern California. Operated by Helicopter Express, the aircraft is based at Fox Field in Lancaster, California, and is the only nighttime firefighting helicopter under contract with the U.S. Forest Service. **Alan Nix Photo**

ROTORBEAT

INDUSTRY ■ OPERATOR ■ OEM ■ UAS ■ INTERNATIONAL



For a short period of time, Helijet's fleet of S-76C+ aircraft, operated on behalf of B.C. Emergency Health Systems, was unable to land at seven hospital heliports in the province.

Heath Moffatt Photo

Heliport rule interpretation puts Canadian HEMS at risk

by Oliver Johnson

Publicly-funded air ambulance services in Canada are being put at risk due to the national regulator's "changing interpretation" of H1 heliport performance requirements, according to Helicopter Association of Canada president Fred Jones.

The issue came to widespread attention earlier this year after Transport Canada informed EHS LifeFlight in Nova Scotia that it could no longer land its Sikorsky S-76A (operated by Canadian Helicopters) at H1 helipads at the

QEII Health Sciences Centre and IWK Health Centre in Halifax, or at the Digby General Hospital, as the aircraft didn't meet the performance requirements for H1 heliport operation.

This was then followed by a similar decision for B.C. Emergency Health Systems' (BCEHS's) Helijet-operated fleet of S-76C+ aircraft, which meant flights to seven hospital helipads in the province were suspended.

As an interim measure, both organizations

were forced to land their aircraft at alternate sites, and then ferry patients to hospitals by ground ambulance.

As of Sept. 15, BCEHS air ambulance flights had resumed at all seven helipads following an exemption order from Transport Canada, which is in place until Jan. 31, 2017. Service was only restored to two hospital helipads — at Royal Columbian Hospital and Surrey Memorial Hospital — after BCEHS contracted Ascent Helicopters to use its MD 902 to

access the facilities. In terms of a longer-term fix, BCEHS said the order would provide Helijet time to work with Transport Canada and Sikorsky to resolve outstanding regulatory requirements.

“BCEHS will continue to work with Helijet and Transport Canada to fully resolve the outstanding regulatory issues that Transport Canada has identified,” said Linda Lupini, executive vice president of BCEHS, in a statement. “As part of our agreement, we expect Helijet to take the necessary action to fully comply with Transport Canada’s requirements, including any necessary equipment or fleet enhancements.”

The Canadian Aviation Regulations (CARs) define H1 heliports in Standard 325.19(1.a) as being located within an obstacle environment where there is no emergency landing area within 625 meters from the final approach and take-off areas (FATO), and the helicopters using the heliport can be operated at a weight, and in such a manner that, in case of an engine failure at any time during approach or take-off, the helicopters can either land and safely stop on the FATO or touchdown and lift-off (TLOF) area, or safely continue the flight to an appropriate landing area.

But it’s the interpretation of the performance requirements for operating from an H1 heliport that is causing a rift between operators and the regulator. CARs Standard 325.19(2.a) states:

“Helicopters permitted to use an H1 heliport shall be multi-engined and capable of remaining at least 4.5 meters (15 feet) above all obstacles within the approach/departure area in accordance with subsection 325.29(3) when operating in accordance with their aircraft flight manual with one engine inoperative.”

According to the HAC’s Jones, while these regulations have been in place since 2007, it’s only recently that Transport Canada’s interpretation of this section has become an issue.

“The way Transport Canada is currently interpreting the standard, they are applying a CAT A [Category A] requirement, which is a certification requirement for the aircraft,” he said. “But CAT A isn’t called for in [CARs] 325 — it only calls for 15 feet above all obstacles, [which] is not even the CAT A performance requirement. CAT A performance calls for 35 feet above obstacles. What’s more, the aircraft flight operations manuals don’t mention H1 — they

only contain CAT A performance charts.”

Jones said CAT A operation also triggers a raft of associated requirements, setting a very high bar for operators.

“It’s a high bar in many ways: a high bar in terms of the heliport infrastructure; the capital cost of CAT A compliant aircraft; and a very burdensome requirement in terms of operational limitations and equipment requirements as well.”

He argued that if Transport Canada had meant to say CAT A in the standards, they should have written them that way, and said operators needed more predictability around the interpretation of the rules as they make large capital investments based on them.

“We believe it’s a problematic and uncertain interpretation and it’s certainly not clear to the industry how it’s supposed to be applied,” he said. “And when I say ‘supposed to be applied,’ I mean based on a reasonable reading of the regulations and standards — because Transport Canada seems to have adopted an interpretation that we believe may be inconsistent with [that].”

The wider impact of Transport Canada’s interpretation would be enormous, on a number of different levels, said Jones — especially due to Canada’s largely publicly-funded model of air ambulance service. “More powerful [and] more costly aircraft may put air ambulance service beyond the reach of some of the provincial ministries of health, and probably beyond the reach of small communities that would otherwise have benefitted from EMS service,” he said. “Because once you’ve started getting into those very costly aircraft, it’s difficult for the customer to support those significantly higher purchase and operating costs.”

Ultimately, Jones said the issue was about giving Canadians access to EMS helicopters. “Canadian EMS helicopter operators have a 40-year safety record that is second-to-none,” he said. “We believe strongly that Transport Canada needs to revisit its interpretation of [CARs] 325 in the context of our long-standing safety record in Canada, or the health and safety of Canadians will be negatively impacted by reductions in EMS service availability across the country.”

To help resolve the issue, HAC held a recent meeting with Transport Canada representatives and five operators to

discuss the current problems and possible solutions.

“The meeting was productive because Transport Canada started to understand some of the problems the industry is facing with this and they started to understand what’s at stake, which is really getting people to lifesaving facilities and care in a safe and timely way from a serious accident,” said Jones. “So, they gained some appreciation for the dilemma that industry was facing, and we’ve agreed to talk again to discuss a reasonable way forward on this.”

When reached for comment, Transport Canada issued the following statement:

“Transport Canada has established a national policy tied to a regulatory standard on heliports that has been in place for a number of years. The department maintains its decision to require the appropriate performance and procedures necessary to comply with the current standards. It is up to the operator to select an aircraft that complies with the requirements for the intended operation. In all cases, the safety of the flight operations, the passengers, and crew remains the top priority, and the department continues to work with affected organizations regarding this matter.”

For now, Jones said the only advice HAC can give its members is to comply with the interpretation that Transport Canada has applied, and to work to identify ways to provide an equivalent level of safety with their existing aircraft.

“We are in the process of obtaining a [legal] interpretation of our own to see if the wording of [the standard] can reasonably support a requirement for full CAT A compliant aircraft,” he said.

And, while the current debate is focused on air ambulance operations, Jones emphasized the issue concerns all general aviation and commercial operations to all H1 helipads.

“Everybody has a vested interest in this,” he said. “We’re trying to work through it on a national level, because even though Canadian Helicopters and Helijet have been at the pointy end of this process, depending on how Transport Canada ultimately interprets the standard, the uncertainty it will affect anyone operating multi-engine aircraft to H1 facilities.”

Bell opens customization building at Piney Flats

by Oliver Johnson

In late July, Bell Helicopter officially opened a new 150,000-square-foot customization building at its facility in Piney Flats, Tennessee, providing the plant with an expanded capability to complete and customize over 200 aircraft a year.

The facility serves as the last link in the delivery chain to the customer, receiving “green” aircraft from Bell’s assembly plants and customizing them to meet customer specification before delivery. It also serves as a maintenance, repair and overhaul service center for about 80 helicopters in the region, has a component repair and overhaul facility, and is home to Bell’s Aeronautical Accessories brand (which has about 4,000 options for accessories).

Prior to the expansion, the customization value streams (light, intermediate, or medium helicopters) were located in separate buildings around the campus and mixed in with the other services at the plant. Now, all customizing operations are together under one roof.

It was a two-year process to convert an existing warehouse and fully establish the customization operations there, with the company’s light helicopters the first to be brought in about a year ago. Once Bell had refined its processes, the medium and intermediate product lines were brought in.

“All three value streams are up and running today,” Chad Nimrick, general manager for Bell Helicopter’s U.S. sites, told *Vertical*. “For the most part, our processes and procedures are working, there’s still a few refinements here and there. We also implemented a new ERP [enterprise resource planning] system as well, during this process. So we kind of did it all at the same time. It added a bit to the pain, but I think it’ll pay dividends very quickly.”

Bell has other customization facilities around the globe, but Piney Flats completes about three quarters of the company’s customization work, which is completed as part of the aircraft sale to configure it to a customer’s mission profile.

“Unless we have a fleet deal, every aircraft that comes out of here is different in some form or fashion,” said Nimrick. “You may have a VIP customer that comes in that



A new customization building will provide Bell’s facility in Piney Flats with the ability to complete and customize over 200 aircraft a year. **Bell Helicopter Photo**

wants a very basic VIP kit with the standard Bell offerings and kits, and then the next customer comes in and would like that — but they would also like some place to mount their iPad, they want USB ports, they want LED lighting.... We can basically do anything that the customer wants.”

The balance of industry segments for which Bell is customizing the aircraft is pretty evenly split between emergency medical services, law enforcement, utility, and VIP, according to Nimrick.

He said turnkey service was the major benefit to the customer of choosing an OEM — rather than a third party — to complete their aircraft. “Being a part of the Bell Helicopter family and organization, we are able to really leverage all of the Bell Helicopter services,” said Nimrick. “Engineering is a big one, obviously — and as part of that engineering service we have about 34 engineers here on site dedicated to both our customizing operation and our manufacturing operation.”

The benefit to customers of the new facility will be faster turnaround times for completions, said Nimrick. “The key aspect is on the front end, where we’re really working

diligently with the customer to get the configuration nailed down, so that we can then start our certification processes, our engineering processes, and our supply chain processes,” he said. “That’s key, because when those get disrupted throughout the completions and customizing value chain, it can disrupt our schedule and push delivery times out.”

It’s been a year of change in Bell’s customer support and services division, with the rebranding of the its site in south Florida as Bell Miami (formerly known as Edward Rotorcraft Solutions), following the launch of its Customer Advantage Plans (CAPs) at HAI Heli-Expo in Louisville, Kentucky, in March.

Nimrick said the CAPs have been taken up by a few smaller customers, and that Bell was in negotiation with “several large operators” about implementing them in their fleets. “From our perspective, that is where our customer support is going to be evolved to,” he said. “We really feel very strongly about that and we believe it’s a differentiator for those customers to get on these plans and then have Bell Helicopter support through the lifecycle of their aircraft from day one.”

S-76D lands in Canada

Fig Air Inc., a Toronto-based VIP and corporate helicopter operator, has signed for a Sikorsky S-76D. It will become the first of the type to be delivered to a Canadian operator.

"We are thrilled to be able to provide Fig Air with such a capable solution to meet their VIP service requirements," said Charles Bouchard, chief executive for Lockheed Martin Canada and a former Royal Canadian Air Force helicopter pilot. "We welcomed Sikorsky to the Lockheed Martin family a year ago, and it is clear they are uniquely suited to provide a diverse range of helicopter solutions to meet Canada's commercial and defense markets."

S-76D VIP options include a customized interior with seating for five to eight passengers. The S-76D has the ability to hold its rotor system still while running an engine to power the on-board air-conditioning system for safe, comfortable loading and unloading into the pre-cooled cabin during the summer season and in hot climates.

Sikorsky has delivered more than 850 S-76 helicopters to customers globally since 1979, contributing daily to nearly seven million fleet flight hours.

Toronto-based VIP and corporate operator Fig Air has ordered what will become Canada's first Sikorsky S-76D helicopter.

Sikorsky Photo



■ RotorBits

LEONARDO SELLS FIVE CORPORATE AIRCRAFT IN S. AMERICA

Leonardo Helicopters Photo



Leonardo Helicopters has announced that five corporate helicopters have recently been sold to three customers in South America. The sales include one Leonardo Helicopters AW169 and two GrandNew helicopters to corporate customers in Argentina, and another two GrandNew helicopters to a corporate customer in Venezuela. All five aircraft will be delivered by the end of 2016.

There are now more than 250 Leonardo Helicopters aircraft operating in South America, across a fleet of AW109s, AW119s, and AW139s.

FIRST EUROPEAN OFFSHORE AW169

Caterina Jahnke Photo



Right on time for the start of the world's largest offshore wind energy project, Siemens Gemini, Heli Service International received the first Leonardo Helicopters AW169. The mid-sized twin-engine helicopter of the 4.8-ton class is specifically designed for demanding offshore applications.

Heli Service International, based in northern Germany, is the first customer to employ this new type on the European helicopter market. The AW169 features a special lightweight configuration and meets the customer's requirements for the transfer of maintenance personnel to and from the wind turbines in an optimum way. It also includes a hoist from Goodrich.

Airbus Helicopters feels Turøy impact

by Thierry Dubois

Airbus Helicopters is reviewing its options after the H225 (EC225 LP) crash that killed 13 people on April 29 in Turøy, Norway, further damaging the reputation of the Super Puma heavy twin family among the offshore workforce. While the root cause of the accident is not yet known, the impact of the accident on the Marignane, France-based manufacturer is palpable.

“[Our] helicopters [division] is still very much impacted by the tragic accident in Norway,” said Airbus Group CEO Tom Enders during an analysts call in late July.

At the time, an Airbus Helicopters spokesman told *Vertical* that “it is too early for us to talk about implications” for the long-term future of the H225 following the crash and resulting grounding of much of the aircraft’s worldwide fleet. Rather, the company is endeavoring to communicate with customers — a lesson learned from previous crises.

The manufacturer is striving to keep proactive. Norwegian investigators have stated their belief that the initiating event in the main gearbox was a fatigue failure, which Airbus is addressing with emergency alert service bulletins (EASBs). An example is a precautionary measure for those helicopters still flying, such as in search-and-rescue or parapublic operations. Two types of epicyclic module second stage planet gears are in service. One has been deemed more reliable. The EASB describes how to replace one with another.

Despite Airbus Helicopters’ efforts, in early June, CHC, the operator involved in the crash, announced a major restriction for the type. It said it no longer intends to use the H225 from Aberdeen, U.K. — its largest base in the North Sea. Only for those customers who “wish to fly the aircraft” will the company “appropriately adjust the mix of aircraft.”

However, this will only take place after civil aviation authorities lift flight prohibition on the H225 and AS332 L2 Super Puma. “We are engaged in discussions with EASA to see when we can release the Super Puma fleet again,” Enders said. He added that 80 percent of the worldwide fleet was grounded. The European Aviation Safety Agency (EASA) and Federal Aviation Administration (FAA) estimate 340 and five aircraft, respectively, are affected by their airworthiness directives. The AS332 L1 — 450 helicopters under the EASA’s oversight — is not affected.

In the history of aviation, very few situations are comparable, said Teal Group analyst Richard Aboulafia. He pointed to the FAA withdrawal of the type certificate for the McDonnell Douglas DC-10 for five weeks in 1973, following the discovery of a serious design deficiency after a fatal accident in Chicago. The tragic event was not the only one in the early years of the program, and contributed to a loss of confidence from airlines at the time, Aboulafia noted.

For Airbus Helicopters, regaining trust from customers, pilots and passengers will be a daunting task. A Norwegian source familiar with the local industry’s reaction said Super Puma safety remains “a big issue among pilots.” The source also said industry members in the country would have liked to have seen more of Airbus Helicopters CEO Guillaume Faury in the media; he gave only one interview to a Norwegian TV news channel, the source said.

The U.K.’s National Union of Rail, Maritime and Transport Workers (RMT) has numerous members working on offshore rigs and thus commuting by helicopter. The RMT heard widespread, strong backlash about the aircraft after the accident — the RMT’s regional organizer in Aberdeen received over 70 related emails in just six days, and all were expressing negative feelings about the Super Puma. This sentiment was echoed in a change.org online petition, purportedly representing North Sea Offshore Oil Workers and their families, which called for the H225 to be permanently removed from service. It received over 27,000 signatures.

Such groups, different from airline passengers, are concentrated and coordinated. They could have some influence, Teal Group’s Aboulafia believes.

Les Linklater, the executive director of Step Change In Safety, an organization dedicated to safety improvement in the offshore

EASA grounded the H225 and AS332 L2 Super Puma types on June 2, and the FAA followed suit the next day.

Anthony Pecchi Photo



oil-and-gas industry, warns against the idea of singling out a type. In a column published on *Energyvoice.com* on May 13, he noted the loss of two Sikorsky S-76s in a six-month period in 2015-2016 in Nigeria, with six fatalities in the first accident. No regulatory response was seen in the U.K. "There was no call to ban this aircraft or the operator from transporting workers to and from offshore installations in S-76s, despite the fact that we continue to use them in the U.K.," Linklater wrote.

The Sikorsky S-92 is the preferred H225 alternative by many in the workforce, he went on. However, the S-92's gearbox has had its share of trouble. In 2009, 17 people lost their lives off the coast of Canada on board this model of aircraft due to gearbox issues, Linklater wrote. An improved main gearbox for the S-92 has been in development since 2013 or even earlier. In February this year, Sikorsky could not give a target date for entry into service.

Asked about the Super Puma's design, Aboulafia says it has been serving "so well and for so long" that he doubts the problem can be "a fundamental design flaw."

At the Marignane factory, H225 production is running at a slow pace. But this would likely have been the same without the accident. The offshore market is "completely down, meaning that not a single order was booked worldwide by any manufacturer in the medium-heavy segment for the oil-and-gas business in the first half of the year," according to Airbus Group's Enders.

Kuwait orders 30 H225Ms

On Aug. 9, Airbus Helicopters signed a contract with the Kuwait Ministry of Defense for 30 H225Ms. The deal includes associated support and services.

The order can be seen as a token of confidence from a long-term customer. "I would like to personally thank the Kuwait Air Force which placed its trust in our products," CEO Faury said. The first delivery, however, will not take place until 2018, thus not boosting the production rate for the short term, according to a union source.

As for the other members in Super Puma family, the H215, which combines the AS332 C1/L1's older dynamic systems with the H225's modern avionics, is not affected by the grounding. The first example is to roll out next year from Airbus's new factory in Romania.

In terms of the military versions of the Super Puma, Airbus hopes to conclude more sales campaigns this year. Poland is the number one prospect, after Kuwait inked a contract in early August (*see sidebar*). French forces have kept the Cougar (the equivalent of the AS332 C1/L1) and the H225M Caracal (the H225's military variant) in service.

The Airbus Helicopters spokesman would not confirm reports that Singapore has postponed, due to the ongoing investigation and grounding, a decision on a \$1 billion military helicopter purchase.

The airframer is proceeding with the development of the HForce generic weapon system that can be adapted to its range of commercial rotorcraft. A firing campaign took place recently with an H225M. One could see this as evidence the manufacturer trusts its design.

The spokesman could not give an update, however, on the development of the upgraded H225. Formerly known as the EC225e, it features an increased maximum takeoff weight and further automation in the cockpit. In February, Airbus Helicopters was planning on a first delivery by year-end.

Further up the design pipeline, the firm has been preparing a replacement for the Super Puma under the X6 codename. Unveiled last year, the X6 is in a two-year "concept phase" until 2017. And, as we're still in the early stages of fallout from the current Super Puma situation, it's unlikely the X6's development will be sped up any time soon. Such an acceleration would also be costly.

In Aboulafia's view, the current circumstances illustrate the benefit of being part of a larger corporation for Airbus Helicopters. When parent company Airbus Group released its first-half financial results on July 27, CFO Harald Wilhelm said "the financial impact [of the H225 situation] cannot be reliably estimated at this stage." And, in addition to the 11 fewer Super Puma deliveries recorded in the first half of the year, "this is going to impact the support business," he predicted.

■ RotorBits

CHC BEGINS MARINER FLIGHTS FOR STATOIL U.K.

CHC Photo



Statoil U.K. Ltd and CHC Helicopter have celebrated the inaugural flight to the Mariner field — Statoil's first operated field development on the United Kingdom Continental Shelf.

"We're proud to partner with Statoil to support operations in the Mariner field," said CHC's regional director Mark Abbey. "With extensive experience of the North Sea environment our pilots, engineers and support teams look forward to providing a safe and reliable service for years to come."

CHC will initially be operating one Sikorsky S-92 aircraft, to support the Mariner B and the Noble Lloyd Noble jack up rig, which is due to be on location later this year. Support will increase to two S-92 aircraft during the main hook up and commissioning phase from mid-2017.

FAA TO HOST 2ND INTERNATIONAL ROTORCRAFT SAFETY CONFERENCE

The Federal Aviation Administration's (FAA's) Rotorcraft Directorate is hosting its second International Rotorcraft Safety Conference. The conference's goal is to reduce the helicopter accident rate in the U.S.

The event, to be held Oct. 25 to 27 at the Hurst Conference Center, near Fort Worth, Texas, is free. The conference will feature presentations from major industry and FAA leaders.

Topics include improving aeronautical decision making, creating a culture of safety, techniques for performing safer autorotations, choosing the best protection equipment, and basic helicopter safety and maintenance.

The FAA's Civil Aerospace Medical Institute will bring its Helicopter Spatial Disorientation Demonstration exhibit allowing attendees to experience various — including dangerous — flight scenarios.

Monsoon Season by Elan Head

In August, a unique demonstration took place at the airport in Nelson, British Columbia — a flying display with one of the first helicopter firefighting buckets, the Monsoon Bucket.

Yes, that's "Monsoon" with a "z". The distinctive spelling was part of the branding for the bucket, which was developed in Nelson and sold in kit form through the 1960s.

The inventors of the bucket were pilot Jim Grady of Okanagan Helicopters — which in the 1950s was the largest helicopter operator in North America — and Henry Stevenson, the owner of Stevenson Machinery Ltd., the Nelson machine shop founded by his father.

As recently described in *Vertical* (see p.114, June-July 2016), aerial firefighting was still in its infancy when Grady and Stevenson conceived of a bucket that could be suspended underneath a helicopter and easily refilled while hovering over a convenient water source.

The partners based their design on a standard oil or gasoline drum, modifying the base of the drum with a valve assembly with electric solenoid release. As with modern firefighting buckets, the pilot could open the valve to release water at the touch of a switch.

According to Henry Stevenson's son, Gerry Stevenson, perfecting the design took plenty of trial and error. "I remem-

ber this as a kid, watching the number of things they were trying," he recalled.

Eventually the inventors developed a functional product, and received a patent for their "helicopter water dumping bucket" in 1965. They sold more than 300 Monsoon Bucket conversion kits across Canada, the United States, and as far away as Australia.

"They would tell people, all you have to provide is the bucket," said Gerry Stevenson. "They [were] quite successful with that for a number of years."

Although the Monsoon Bucket was eventually replaced by larger and more portable products, it had a lasting influence on the aerial firefighting industry. It also found some other applications, including stocking remote mountain lakes with fish fingerlings.

"I always think of it as my family's legacy," said Stevenson.

Henry Stevenson passed away last year at the age of 99, but his wife, Audrey, turned 90 this summer. With the family gathering in Nelson for the birthday celebration, the Stevensons had a unique opportunity to also celebrate Harry's legacy.

Gerry Stevenson had previously managed to track down an original Monsoon Bucket in a hangar in Penticton, B.C., and this reconditioned bucket was loaned to the Stevenson family for a flight demonstration. On Aug. 13, 2016, with Kootenay Valley Helicopters pilot Jeff Parker at the

controls of an Airbus Helicopters H125, the Monsoon Bucket flew again.

"It flew great," Parker told *Vertical*. "You could probably go fight fire with that bucket today."

Because the bucket's solenoid valve was intended for a lower voltage electrical system, Kootenay Valley Helicopters' Rob Taylor used a voltage converter with it as a precaution, but he said that the set-up was otherwise straightforward.

The Monsoon Bucket that was used for the demo has been promised to a museum, but Gerry Stevenson hopes that there are still a few out there that haven't yet been turned into fire pits.

"I would really like to know if there's another one that shows up," he said.

Developed in the 1960s, the Monsoon Bucket still performs surprisingly well today, according to pilot Jeff Parker. **Douglas Noblet Photo**



The family of Monsoon Bucket co-inventor Henry Stevenson gathered in Nelson, B.C., on Aug. 13 as Kootenay Valley Helicopters put on a flying display with an original bucket. **Douglas Noblet Photo**





HOT. HIGH. AND VERY COOL.

WAY MORE PAYLOAD.

The Eagle Copters conversion improves the payload capability of your Bell 407 helicopter by an estimated 34% at 10,000 feet, significantly increasing the aircraft's capability over a wider operating spectrum. The powerful new Honeywell HTS900 engine delivers an output of 1,021 shaft horsepower — a 22% improvement in output at high and hot conditions over the incumbent engine.

[**hothighandverycool.com**](http://hothighandverycool.com)

Mount Otto, Papua New Guinea | 11,300 feet | AUW 5,250 pounds

Airbus improves H175 despite down market

by Thierry Dubois



This year marks the delivery of the first two Airbus Helicopters H175s in a VIP layout. The manufacturer said the aircraft provides a “jet-like” flying experience, largely thanks to advanced soundproofing. **Anthony Pecchi Photo**

Airbus Helicopters is continuing its improvement plan for the H175 super medium twin, despite the main market for the model — oil-and-gas — being down and showing little sign of an upturn.

“By the end of the year, we expect certification for flight into limited icing conditions,” program director Marc Allongue told *Vertical*. In the same period, the 16- to 18-seater will have its maximum takeoff weight (MTOW) increased to 7.8 metric tons (17,180 pounds). This will translate into a 300-kilogram (660-pound) payload enhancement or an additional 40 nautical miles in range. Certification of the Rig’N Fly system for more automated approaches to oil rigs is scheduled “before next summer,” said Allongue.

Development of the public services version should culminate with certification in the third quarter of 2017. Missions may include search-and-rescue, emergency medical services and law enforcement. The first units of this variant will reach the market in late 2017, the launch customer being Hong Kong’s Government Flying Service.

This year, the Step 2+ version of the Helionix avionics suite (which includes a synthetic vision system) was approved, along with ADS-B Out, search-and-rescue modes, flight in snow conditions and an aft extension of the center of gravity range.

Moreover, the U.K. Civil Aviation Authority has given its nod for the H175 to use two helipads — in the North Sea — that were initially designed for the smaller Sikorsky S-76. “This paves the way for being allowed into more oil platforms everywhere in the world,” Allongue said. A dedicated test campaign had taken place early in the program, during the development phase.

Late last year, the flight envelope was expanded in altitude and hot weather. Moreover, the autopilot was fully coupled to the traffic collision avoidance system (TCAS) for automatic traffic avoidance, Allongue added.

All this progress is taking place against a backdrop of slow sales and deliveries. Across the industry, almost no orders were taken from the oil-and-gas market segment last year, but the H175 was a notable exception — at 36 orders, the company’s sales team exceeded their objective. Overcapacity at offshore operators, combined with the unlikelihood of a substantial increase in oil price, will make the overall trend unchanged in 2016 and 2017, in Airbus Helicopters’ view.

Nevertheless, 10 H175 deliveries are planned in 2016. Noteworthy was the first VIP aircraft, featuring a cabin interior from Pegasus Design, which was delivered in July. Distinctive are the hinged door — which optimizes space inside the cabin

and enables better soundproofing — an electric footstep and electronically dimmable windows. A second VIP H175 is to be delivered by year-end.

This year, the unnamed VIP customer and Transportes Aéreos Pegaso, a company specializing in air transport services for the energy industry in the Gulf of Mexico, have become the second and third operators. NHV was first. The Belgium-headquartered company has been operating in the North Sea since late 2014 and, more recently, in Ghana.

Russia’s UTAir is officially an operator, but the only H175 delivered has been leased back to Airbus Helicopters, which is using it for marketing purposes.

As of late August, the fleet had logged 5,000 flight hours. The “availability rate,” not counting scheduled maintenance, was calculated at 90 percent in 2015. Airbus is planning on a similar percentage in 2016 — the first year with more than one operator.

A total 11 H175s have now been delivered, 10 of them being in commercial service. These numbers are far from initial expectations. In May 2014, 21 deliveries were planned over the 2014-2015 period.

The backlog of firm orders stands at 61. In 2017, Airbus is targeting 15 H175 deliveries.



PEOPLE MAKE IT POSSIBLE

"The U.S. Army had corrosion problems with the transmissions of their Chinook fleet; we had the solution. We fly Chinooks so we know the problems and how to fix them."

Paul Leach is the Director of Military Maintenance for Columbia Helicopters. With 5 years of military service and 23 years with Columbia, he's the man for the job. Paul is a native of Oregon, decorated Gulf War Vet, and one of the over 800 proud employees that separate Columbia Helicopters from the rest.

"Seeing our solutions make a difference for the folks who defend our freedom, that's what I get excited about. There is no better feeling than knowing we're helping our soldiers come home safe."



*Experience to fly,
Knowledge to Maintain.*

Read Paul's full story and others at colheli.com/ourstory/faces.

Chinese students train in Canada



Twenty Chinese students arrived in mid-July for preparatory classes, and as *Vertical* went to press, official flight training was expected to start sometime in mid-September, depending on regulatory approval.

National Helicopters Photo

Air Transport Association of Canada (ATAC) members Ottawa Aviation Services (OAS) and National Helicopters Inc. have entered into an innovative partnership to offer helicopter training to groups of Chinese students. The companies expect to host hundreds of Chinese helicopter students over the next three years.

“National Helicopters and Ottawa Aviation Services won this contract against other cheaper international bids despite regulatory and economic headwinds,” said Cedric Paillard, CEO of OAS. “At the end, quality of flight training was the deciding factor.”

OAS will be managing the entire project, including offering aviation English and ground schools as required. National Helicopters will provide the flight training component. The first intake of 20 Chinese students has arrived and started commercial ground school. National Helicopters will be offering the training out of the airport in Cornwall, Ontario.

OAS has also entered into an agreement with the Nav Centre in Cornwall to host this group of students and other domestic and international students in OAS’s integrated and other training programs.

The Nav Centre is the largest facility of its kind in Eastern Ontario, offering world-class education facilities and technology, air traffic control simulation capabilities, accommodation and recreational facilities. At this location, OAS expects to offer domestic and international students an exceptional flight training and life experience in Cornwall and in Canada.

“We are very pleased to have entered into this agreement with Nav Canada and National Helicopters,” said Paillard. “We are working together to establish a campus in Cornwall that will support the training of hundreds of domestic and international students. We look forward to working with Nav Canada, the Nav Centre, the City of Cornwall and surrounding communities to place the Cornwall area on the map of professional pilot training destinations.”

“National Helicopters Inc. is very excited to partner with our ATAC associate, Ottawa Aviation Services,” added Dan Munro, president, National Helicopters Inc. “This is a strategic partnership with the Cornwall Nav Centre, which brings two of Eastern Canada’s foremost flight training schools together. The quality of flight training at our respective schools has been recognized on the world flight training stage.”

“We are excited about this opportunity with OAS to establish world-class pilot training programs at the Nav Centre,” said Kim Coe-Turner, general manager, Nav Centre. “It is a perfect fit for [the] Nav Centre and augments what Nav Canada offers internationally.”

R66 TURBINE

- 5 seats + baggage compartment
- Garmin G500H & HeliSAS options
- Optional auxiliary fuel tank

\$869,000 Base Price

ROBINSON
HELICOPTER COMPANY

www.robinsonheli.com

MORE THAN 600 PILOTS ARE FLYING HeliSAS!



WHY AREN'T YOU?

HELISAS.® LIGHTEST, MOST COMPACT AUTOPILOT
AND STABILITY AUGMENTATION SYSTEM. PERIOD.



GENESYS HeliSAS®

There's a reason so many pilots are choosing HeliSAS.

Hands-free autopilot and stability augmentation in the lightest, most compact package—ideal for Part 27 helicopters.

- Less than 15 pounds
- Safer, more confident command...even under demanding conditions

- Dramatically reduced pilot workload
- Auto-recover to a neutral attitude in situations where pilot may lose visual reference
- Pilots with no helicopter experience have successfully hovered a HeliSAS-equipped helicopter with little practice

Visit our website to see if HeliSAS is right for you!



Sign up on our website for the latest Email News & Updates!



genesys-aerosystems.com | 1-817-215-7600

▪ RotorBits

HFI SCHOLARSHIPS OPEN

Helicopter Foundation International (HFI) began accepting applications for its Commercial Pilot Rating and Maintenance Technician Certificate Scholarships on Sept. 1, 2016.

Applicants for the Commercial Pilot Rating Scholarship must already have obtained their private license and be enrolled in a commercial helicopter rating program at a Federal Aviation Administration (FAA)-approved part 141 school or international equivalent. Up to four scholarships may be awarded.

Applicants for the Maintenance Technician Certificate Scholarship must already be enrolled in a maintenance technician certificate program at an FAA-approved part 147 school or international equivalent. Up to six scholarships may be awarded.

The application deadline is midnight EST Nov. 30, 2016.

XTI LAUNCHES SERIES B FINANCING

XTI Aircraft Company Image



XTI Aircraft Company has launched the next phase of its funding strategy to bring the TriFan 600 to market.

In addition to its ongoing equity crowdfunding campaign, XTI entered into an engagement agreement with the New York investment bank Primary Capital LLC, for XTI's \$20 million Series B round.

XTI said the six-seat TriFan 600 will have the speed, range and comfort of a business jet and the ability to take off and land vertically like a helicopter. Using three ducted fans, the aircraft will lift off vertically and its two wing fans rotate forward for a seamless transition to cruise speed, at 400 miles an hour (643 kilometers per hour) and a range of up to 1,600 miles (2,575 kilometers).

AW609 resumes flight tests



The first AW609 prototype resumed flight testing in August, and the manufacturer said it is still aiming to certify the aircraft in 2018. **Leonardo Helicopters Photo**

The first Leonardo AW609 tiltrotor prototype has resumed flight testing in helicopter and airplane modes, the manufacturer announced in August.

Following the resumption of flight testing activities in Arlington, Texas, Leonardo relocated the aircraft to its facility in Philadelphia, Pennsylvania, after an overnight stop in Hunstville, Alabama. The aircraft was then scheduled to be relocated to Italy.

Testing is due to resume in Philadelphia with the arrival of the third prototype from Italy. A further aircraft is currently being assembled in the Philadelphia plant, and it is scheduled to join the test fleet in 2017.

Before resuming in August, flight tests in the AW609 had been on hold since the fatal crash of the second prototype on Oct. 30, 2015, which killed test pilots Herb Moran and Pietro Venanzi.

In an interim statement released on June 23, Italy's National Agency for Flight Safety (ANSV) reported that the accident aircraft experienced a kind of "augmented Dutch roll" while diving to an extreme maximum speed of 293 knots as part of the flight testing required for certification. The resulting oscillations appear to have led to a

catastrophic in-flight breakup.

The accident flight was the first time the AW609 reached a maximum dive speed of 293 knots with rear fuselage and tail fin modifications — enhancements that were introduced in 2013 to reduce the aircraft's drag and enhance performance.

Noting that the aircraft's behavior at high speed was not completely predicted by the manufacturer, the ANSV recommended further review of the AW609's aerodynamic behavior at high speeds, as well as a review of the model's fly-by-wire flight control laws to ensure the effectiveness of pilot inputs.

In May, shortly after its first ground runs, the third AW609 prototype was sequestered by Italian prosecutors in conjunction with their investigation into the accident. It was then released back to Leonardo in July.

At the time of the third prototype's release, the manufacturer said it continues to cooperate with all relevant authorities involved in the investigation of the second AW609 crash, and still plans to meet "the previously announced and expected program schedule" to certify the aircraft in 2018.

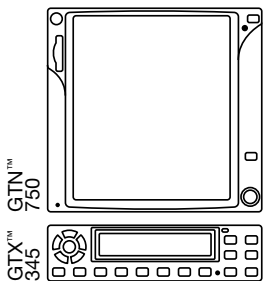

GTX™ 345. ADS-B TOOLS AS UNIQUE AS YOUR OPERATIONS.

Increase your mission effectiveness with the Garmin GTX 345 all-in-one ADS-B transponder. Get ADS-B Out plus ADS-B In weather and helicopter-optimized traffic on GTN™ navigators, select Garmin portables and mobile devices using Garmin Pilot and ForeFlight Mobile. All with the same footprint as most existing transponders. Learn more at Garmin.com/ADS-B.





The Helicopter Flight Training Center, in Shreveport, Louisiana, has received FAA certification of its Frasca Bell 407 Level 7 flight training device as a BH407GX with night vision goggle capabilities. **Frasca Photo**



ALL BAND MODULES AVAILABLE

VHF / UHF R1-R2 / 7-800

TDFM-9000 SERIES

- ANALOG • DIGITAL • P25
- MULTI-BAND AIRBORNE AM/FM TRANSCEIVERS



TECHNISONIC

www.til.ca - (905) 890.2113 • Distributed by Dallas Avionics • (800) 527.2581

FAA certifies Bell 407GX sim

The Frasca Bell 407 Level 7 flight training device at the Helicopter Flight Training Center (HFTC) is now Federal Aviation Administration (FAA)-certified as a BH407GX with night vision goggle (NVG) capabilities.

The new certification allows the training center to take the cockpit from analog to glass, a change that will take place about once a month for students flying the Bell 407GX.

The cockpit allows for inadvertent entry into instrument meteorological conditions (IMC) training with eight projector screens providing outstanding visuals, including low, medium and high illumination NVG training.

“We are looking forward to training pilots flying both the BH407 and BH407GX in our flight training device,” said HFTC director Terry Palmer. “It takes just four hours to go from an analog cockpit to a glass cockpit, and we will schedule training so that we can accommodate operators using either airframe.”

The flight training device is available to operators for dry lease, which allows operators to use their own instructors and training curriculum.

Programs that do not have an instructor can request a referral from the HFTC or take advantage of its “train the trainer” program.



DOING IT RIGHT
To better connect
the world

Unlock Value In Your Supply Chain

Turn your supply chain into a value chain with aggregated aviation services from global leader AAR. Our supply chain solutions range from individual component repair to complete rotatable inventory management, leveraging our global warehouse network and seamless IT platforms. It's everything you need, when you need it. As an independent services provider, AAR is a single source for efficiency and cost savings. For more than 60 years, we have partnered with our customers to create custom programs and we pride ourselves on doing it right.

AAR is now offering our aftermarket expertise to rotorcraft, so be among the first to take advantage of services from a fellow heli operator.



Visit us at
Helitech
Booth 10D10

WWW.AARCORP.COM
+1 800.422.2213 – WORLD HQ
+1 321.339.9057 – ROTORCRAFT

PARTS SUPPLY | COMPONENT REPAIR | PART 145 MRO | AIRLIFT TRANSPORT | SEARCH & RESCUE

Safran delivers first U.S.-built Arrius 2R



The Safran Arrius 2R powers the new Bell 505 Jet Ranger X. Developed to meet an ambitious timeline, the engine was certified in December 2015. **Safran Photo**



Safran Helicopter Engine employees celebrated the landmark first delivery of a U.S.-made Arrius 2R at the manufacturer's plant in Grand Prairie, Texas. **Safran Photo**









INNOVATIVE SOLUTIONS TODAY AND TOMORROW

- Commercial, Government and Military Platforms
- Parts Distribution
- Helicopter Avionics and Connectivity Solutions
- Special Mission System Integration
- Component Repair, Overhaul and Exchange
- Helicopter Maintenance and Modification
- On Shore/Off Shore Transportation (Brazil)
- Training Systems and Operations Support

HeliviaAeroTaxi

ProfessionalAircraft
ACCESSORIES

SummitAviation

GREENWICHAEROGROUP.COM

Safran Helicopter Engines has delivered — on schedule — the first Arrius 2R engine made in the U.S. Celebration of this handover to Bell Helicopter took place at Safran Helicopter Engines' U.S. facility in Grand Prairie, Texas. It marks a major step in the 2R program and Safran's commitment to supply Bell Helicopter with best-in-class products, assembled in the United States.

The Arrius 2R powers the new Bell 505 Jet Ranger X light single-engine rotorcraft. Until now, units had been assembled at Safran Helicopter Engines' headquarters located at Bordes, in the southwest of France.

"Safran Helicopter Engines can claim a long and successful partnership with customers in the United States, and we are proud to have a member of the Arrius family in production at Grand Prairie," said Jean-François Sauer, Arriel and Arrius programs vice president. "Having this engine produced in the United States will simplify the delivery process to Bell with greatest reactivity."

Formally launched at the 2013 Paris Air Show alongside the Bell 505, the Arrius 2R has followed a fast development schedule. A rigorous evaluation campaign started in April 2014 with its first ground run.

The flight test program started in November 2014 with the first flight of the Bell 505 at Bell Helicopter's Mirabel facility. The Arrius 2R was certified in December 2015, and will be offered with a 3,000-hour time between overhaul at service entry.

To date, more than 3,150 Arrius engines have been sold by Safran, to 430 customers in 60 countries.

Give your business
the lift it needs.



Watch your mobile device come to life with an entire package of flight management services from Cirro software. Cirro is the affordable flight management app that automates the compliance process of flight planning. Want to improve your bottom line? Cirro is designed with fleet owners in mind. With a simple monthly subscription, you will eliminate much of the paperwork that keeps your pilots on the ground, while also making it safer for them in the air. To explore all of Cirro's features go to www.getcirro.com.

■ RotorBits

ERA NAMES NEW DIRECTOR OF SAFETY & COMPLIANCE

Era Group Inc. has appointed David Zaworski director of safety and compliance. With over 17 years of experience in the aviation industry, Zaworski rejoins Era to oversee the company's commitment to maintain the highest safety standards.

"David brings a wealth of industry experience combined with extensive knowledge of Era's operations and procedures and a demonstrated commitment to quality assurance in his prior role as Era's chief inspector that make him uniquely qualified to lead our efforts to maintain the highest safety standards and ensure regulatory compliance," said Era's president and chief executive officer, Chris Bradshaw.

LCI APPOINTS NEW VICE PRESIDENT



LCI Photo

Lease Corporation International has appointed Christopher Grainger to the role of vice president of marketing for the EMEA region. Grainger joins LCI with

30 years' experience in the civil helicopter industry, and was previously vice president of oil-and-gas sales for Airbus Helicopters.

"Christopher's caliber and proven industry experience make him a welcome and significant addition to our team," said Crispin Maunder, executive chairman of LCI. "He will play a key role in the growth of our helicopter customer base covering not only oil-and-gas, but a range of major growth sectors including emergency medical services, offshore wind servicing, utility and search-and-rescue."

LCI's helicopter division comprises a fleet of 90 helicopters delivered or on order or under management. Its helicopters are currently in operation across four continents.

Airbus Helicopters delivers first H175 to be operated in the Americas



Mexico's Transportes Aéreos Pegaso has become the first company to operate the H175 on the American continent. The aircraft will provide transport services for the oil industry and support seismic exploration in the Mexican waters of the Gulf of Mexico. **Airbus/Fernando Dominguez Photo**

Transportes Aéreos Pegaso has become the first company to operate the seven-ton class H175, following the aircraft's arrival in Mexico at the end of August. Pegaso, a company specialized in air transport services for the energy industry in the Gulf of Mexico, will receive a second H175 in 2017.

The new aircraft will not only provide transport services for the oil industry, but also support seismic exploration activities in the Mexican waters of the Gulf of Mexico.

"We have many years of experience with Airbus Helicopters and we are very proud to be among the first to operate this new helicopter, which has become the industry's benchmark medium-sized twin-engine rotorcraft," said Pegaso CEO Enrique Zepeda Navarro. "We are proud to offer our customers a safe, comfortable and quiet helicopter that is also highly cost-effective and easy to maintain."

Transportes Aéreos Pegaso has a fleet of more than 30 Airbus Helicopters rotorcraft, mainly H145s and H135s, but also H130s and H155s. A few months ago, Pegaso signed a framework agreement for 10 H145s and will be among the first Latin American customers to operate the light twin.

"This delivery reaffirms the relationship of trust that Airbus Helicopters and Transportes Aéreos Pegaso have built up over more than three decades," said Francisco Navarro, general manager of Airbus Helicopters in Mexico. "Our customers are a vital part of what we do at Airbus Helicopters; this is why the delivery we are now celebrating comes with our commitment to provide Transportes Aéreos Pegaso with a service that meets all the quality and safety standards that characterize our company."

Transportes Aéreos Pegaso's H175 is equipped with the most advanced version of the Helionix avionics suite, which includes a four-axis autopilot designed to ease crew workload while offering high safety levels.

New avionics features include the auto-hover function and LPV function (localizer performance with vertical guidance) to provide pilots with state-of-the-art piloting and navigation aids.

Since its entry into service in December 2014, the H175 has been flying in support of the oil-and-gas industry in the North Sea — one of the world's harshest operational environments — and in Western Africa.

FAA accepts industry part 27 IFR recommendations

The Aircraft Electronics Association (AEA), American Helicopter Society International (AHS), General Aviation Manufacturers Association (GAMA), and Helicopter Association International (HAI) have welcomed the Federal Aviation Administration's (FAA's) acceptance of industry recommendations to propose an alternative acceptable means of compliance for single-engine helicopters to meet instrument flight rules (IFR) certification requirements for part 27 rotorcraft.

In his response to an industry whitepaper submitted in 2015, Lance Gant, manager of the Rotorcraft Directorate, wrote that the FAA "has begun the process of adopting some of the concepts and recommendations of the whitepaper into a proposed Safety Continuum for part 27 Systems and Equipment Policy Statement."

Gant noted the proposed policy statement — which the FAA expects to release for public comment by December — will create "classes" of part 27 rotorcraft up to 7,000 pounds (3,175 kilograms) based on factors including weight and passenger capacity.

The recommendations came after 18 months of collaboration among aircraft and avionics manufacturers, operators, and industry safety experts, and was co-signed by senior leadership from AEA, AHS, GAMA, and HAI.

They addressed issues — such as reducing the cost and complexity of certifying single-engine rotorcraft — which the industry views as key to increasing the number of IFR operations and improving safety. One of the longstanding concerns within the industry is that the current means of compliance with Advisory Circular 27-1 is viewed as an impediment to single-engine IFR certification due to requirements that essentially make routine single-engine certification economically impractical in spite of the safety benefits.

"We are very encouraged that the FAA not only appears to be supportive of the whitepaper, but is adopting a much more tenable overall approach to leveraging advances in technology for safety and

efficiency," said AHS executive director Mike Hirschberg.

HAI president and CEO Matt Zuccaro said, "I am sincerely appreciative of the FAA's support of this very important initiative. By recognizing the technological

advancements the industry has undergone and the outdated regulatory requirements being applied to single-engine IFR certification, we are now able to move forward with improvement of industry safety and operational efficiency."



ALPINE AEROTECH LP
WORLDWIDE HELICOPTER SUPPORT

At Alpine Aerotech we pride ourselves on our industry leading service expertise, product knowledge, high standards of craftsmanship and long standing tradition of excellence.

- International Credentials and Approvals
- Bell Major Inspections and Overhauls
- Hull Exchange Program
- Approved Structural Capabilities and Fixtures
- Radio and Avionics Repair & Installations
- Component Overhaul Services
- Airbus AS350 Major Inspections
- Manufacturing
- Part Sales

VIEW OUR PRODUCT SITE
AALPRODUCT.COM

1-855-500-2376
Parts Sales: sales@alpineaerotech.com General Inquiries: info@alpineaerotech.com
www.alpineaerotech.com
KELOWNA & ABBOTSFORD BC, CANADA

VISIT US AT STAND 12E51

VISIT US AT BOOTHS 206 - 201



Paradise Helicopters signs fleet for Bell Helicopter CAP

Paradise Helicopters, a leading helicopter tour company in Hawaii, has signed its fleet of Bell 407s to Bell Helicopter's Customer Advantage Plan (CAP). Paradise is the first helicopter tour company to enroll in the new service.

Bell's CAPs provide customers with comprehensive coverage solutions for their operations, with a fixed-price-per-flight-hour that provides predictable maintenance costs, priority access to parts and assemblies, and ease of maintenance and planning.

Under the CAPs, Able Aerospace is the unique provider of all dynamic component repair, overhaul and accessories solutions, utilizing decades of experience and an extensive offering of Federal Aviation Administration (FAA)-approved proprietary repairs.

"We look forward to providing Paradise Helicopters with this simple, reliable and cost-effective solution for its fleet of Bell 407s," said Glenn Isbell, executive vice president of customer support and services for Bell Helicopter.

Calvin Dorn, CEO of Paradise Helicopters, said: "This innovative program helps us know what our costs are per hour, offering complete direct maintenance cost protection and no required buy-in for our installed fleet. It also underscores our continued commitment to safety and reliability throughout our operations, which we have provided to our customers for nearly two decades."

Based in Kona, Paradise Helicopters is an award-winning air tour company that is widely recognized for its safety practices and helicopter experiences on Oahu, Lanai, Maui and Hawaii Island. Paradise recently became the first air tour company in the world to be certified by Helicopter Association International's new Accreditation Program of Safety (HAI-APS).

In addition, Paradise is one of only two helicopter companies in Hawaii to complete IS-BAO Stage 2 certification, which is granted by the International Safety Board and includes stringent requirements.



Field Maintenance for Bell 206, 206L, 205, 212, 412 and Robinson R22 and R44.

Dynamic and hydraulic component overhaul and part sales for the Bell 204, 205, 206, 206L, 212, 407 and 412.

Structural Repairs Fixtures for Bell 206, 206L, 407, 205, 212, 412.

Approved Woodward HRT Licensed Repair Service Facility
Approved Bell Helicopter Customer Service Facility

Transport Canada Approval # 3/86
EASA Approval Number 145.7106

Helitrades Inc.

WOODWARD  

Head Office:
18 Terry Fox Dr., Vankleek Hill, ON, K0B 1R0
T: 613.678.3027 F: 613.678.2776
Gerry@helitradesinc.com

WOODWARD 

Alberta Facility:
Site 5, Box 7, RR2, Airdrie, AB, T4B 2A4
T: 403.912.4658 F: 403.948.6475
info@helitradesab.com

Ontario Facility:
4536 Side Rd 10,
New Tecumseth, ON L9R 1V4
Phone: (705) 435-4031
Gerry@helitradesinc.com

WE HELP AVIATION SALES PROFESSIONALS GENERATE DEALS



**AMSTAT PROVIDES INDUSTRY LEADING CORPORATE
AIRCRAFT MARKET & FLEET DATA**

- ▶ Jets
- ▶ Turboprops
- ▶ Turbine Helicopters

In a suite of comprehensive services to meet every business need



A M S T A T
Information that moves you forward

US 1 877 426 7828 | Int'l +1 732 530 6400 | www.amstatcorp.com

HD Video & Data Downlinks



**Special
HD
Upgrade
Program**

Long Range Real-time HD Video & Data Links

BMS video and data links set the industry standard for reliable, robust real-time performance. Contact your BMS representative for information on special programs to upgrade legacy standard definition systems with HC4 high definition H.264 transmitters with IP and KLV metadata support.

- High power long range transmitters
- Low-latency H.264 HD video encoding
- Secure encryption
- LiveFeed IP network distribution systems
- New CV4 HD handheld receivers



HC4
Transmitter

BMS

BMS – The Downlink Experts

LAW ENFORCEMENT · FIRST RESPONDER · SECURITY · ISR

sales@bms-inc.com · www.bms-inc.com · +1 858 391-3050 / +49 (0) 6128 7408 200

AHI to offer anti-bird strike kit as option

Airbus Helicopters, Inc. and Precise Flight Inc. have entered into a supply agreement for the Pulselite bird strike prevention system, which will be offered as an option on all Airbus Helicopters models marketed in the United States.

The Pulselite System is a Federal Aviation Administration-certified lightweight electrical system controller that alternately pulses the landing and auxiliary lights of a helicopter, thereby increasing its visibility and reflecting the speed and directional movement of the aircraft. The Pulselite System has been shown to reduce bird strikes up to 66 percent, according to Precise Flight.

“Airbus Helicopters is committed to being the industry leader in safety and innovation,” said Lindsay Cunningham, Airbus Helicopters’ director of aviation safety. “Bird strikes are a growing problem for helicopter operators. We are optimistic that the

Pulselite System will help to reduce the number of occurrences, and we are proud to offer it as an option to our customers.”

Increased media attention on bird strikes, including the recent motion picture starring Tom Hanks about U.S. Airways Flight 1549 that was forced to land in the Hudson River after multiple bird strikes caused engine failure, has increased public awareness of the threat of bird strikes.

“The *Sully* Sullenberger movie has directed significant public attention to the threat of bird strikes and has elevated the related safety conversations among aviators,” said Doug La Placa, chief executive officer of Precise Flight. “Offering the Pulselite System as a safety option to their customers is a great example of Airbus Helicopters, Inc.’s industry-leading commitment to safety, and their ability to quickly respond to the ever-changing conditions of aviation.”

FAA’s new drone rules in effect

The Federal Aviation Administration’s (FAA’s) long-awaited regulations for routine non-recreational use of small unmanned aircraft systems (UAS) went into effect on Aug. 29. The FAA said the provisions of the new rule — formally known as part 107 — were designed to minimize risks to other aircraft and people and property on the ground.

“The United States has been a pioneer in aviation since the Wright Brothers first took to the skies more than 100 years ago,” said the Association of Unmanned Vehicle Systems International’s (AUVSI’s) president and CEO Brian Wynne, who was part of a press conference marking the historic moment that U.S. skies opened up to commercial UAS. “[Now] we’ve reached another significant milestone. With the small UAS rule now in effect, the commercial drone industry is cleared for takeoff.”

Wynne added that the UAS industry is poised to become one of the fastest-growing in American history. AUVSI’s economic report has forecasted that the UAS industry will create more than 100,000 jobs and generate more than \$82 billion for the economy in the first decade following UAS integration into the national airspace.

“The small UAS rule establishes a clear regulatory framework and helps to reduce many barriers to civil and com-

mercial operations,” Wynne said. “In reducing those barriers, the rule allows businesses and innovators to harness the tremendous potential of UAS and unlock the many economic and societal benefits the technology offers.”

The FAA said that if a user’s proposed operation doesn’t quite comply with part 107 regulations, they’ll need to apply for a waiver of some restrictions. Users will have to prove the proposed flight will be conducted safely under a waiver, which must be applied for online.

Operators can fly their drone in Class G (uncontrolled) airspace without air traffic control authorization, but operations in any other airspace need air traffic approval. Operators must request access to controlled airspace via the FAA’s electronic portal, not from individual air traffic facilities.

While requests were accepted from Aug. 29, air traffic facilities will receive approved authorizations according to the following tentative schedule: Class D and E surface area, Oct. 3, 2016; Class C, Oct. 31, 2016; Class B, Dec. 5, 2016.

The FAA said it will try to approve requests as soon as possible, but the actual time will vary depending on the complexity of an individual request and the volume of applications it receives. It advised operators to submit a request at

least 90 days before they intend to fly in controlled airspace.

Testing centers nationwide are now able to administer the aeronautical knowledge test required under part 107. After operators pass the test, they must complete an FAA Airman Certificate and/or Rating Application to receive their remote pilot certificate online.

The FAA said it may take up to 48 hours for the website to record that an operator has passed the test. The FAA expects to validate applications within 10 days, and operators will then receive instructions for printing a temporary airman certificate, which is good for 120 days. The FAA will mail permanent Remote Pilot Certificates within 120 days.

The new regulations don’t apply to model aircraft operations that meet all the criteria specified in Section 336 of Public Law 112-95 (which is now codified in part 101), including the stipulation they be operated only for hobby or recreational purposes.

“We look forward to continued industry-government collaboration that advances UAS research and paves the way for a true, holistic plan for full UAS integration, including beyond line-of-sight operations, flights over people, access to higher altitudes, and platforms above 55 pounds,” said Wynne.



THE 21st CENTURY MEDEVAC AUDIO AND COMMUNICATION SOLUTIONS

JA95-N22 & JA95-N32

- ICS Tie Line isolate function (JA95-N22)
- Call Switch (JA95-N32)
- Patient audio on/off function (JA95-N32)
- Tx capability for up to 4 users (2 per unit)

JA95-N70

- Individual receive audio volume controls
- Field replaceable legends
- Standard white or NVG compatible lighting
- Tx capability for pilot, co-pilot & 2 passengers
- Rx Mute input



wiJAC-D01

- Wireless Headset Adapter with Radio Tx
- On board charging through micro USB port
- Range: 328 ft. [100 m] (typical)
- Headset Type: Aviation High Impedance

AS9100 CERTIFIED

800-527-2581 | 214-320-9770

DALLAS AVIONICS, INC.

www.dallasavionics.com



Global Helicopter *MMRO* Specialists

COMPONENTS | AVIONICS | STRUCTURES | STC DEVELOPMENT | MANUFACTURING



Contact the VIH TEAM today!

vihasales@vih.com | 250-655-6821

www.vihaerospace.com

North Slope Borough receives S-92

North Slope Borough (NSB), Alaska, has taken delivery of an S-92 to be used for the critical mission of search-and-rescue (SAR) operations.

“Operating search-and-rescue missions on the North Slope is critical to the life and safety of our residents,” said North Slope Borough Mayor Charlotte Brower in a Sikorsky press release announcing the order. “There isn’t another rescue provider for several hundred miles and with our extreme climate every minute we cannot launch is another minute someone is potentially being exposed to -40 weather, getting frostbite and worse. The gravity of the missions we take on requires that our equipment is uniquely capable of and outfitted for speed and a long reach in icing conditions when someone’s life hangs in the balance. We are pleased to be adding a Sikorsky helicopter to our fleet to better meet those needs.”

The aircraft was selected to provide a safe, efficient and reliable airborne response to medevac requests, SAR and other emergencies. NSB is located above the Arctic Circle and operates under some of the harshest cold weather conditions in the world, with temperatures as cold as -55 C (-67 F) with the

wind chill. According to the U.S. Census Bureau, NSB has a total area of 94,796 square miles, of which 88,695 square miles is land and 6,101 square miles is water — thus the need for a long-range, all-weather capable aircraft.

The order for the aircraft was announced at Helicopter Association International Heli-Expo 2015 in Orlando, Florida. “The North Slope is a unique environment with difficult weather conditions and a vast area of land and sea to cover,” said April Brower, NSB’s search-and-rescue director, at the signing ceremony. “The missions we operate are truly life or death endeavors, and for the safety of our residents we have been committed to identifying the best equipment for our needs. I’d like to thank the team at the North Slope for their continued efforts and Sikorsky for sharing in our commitment to providing excellent service to the people of the North Slope.”

In a milestone year, the global S-92 fleet of over 275 aircraft have surpassed more than one million flight hours since its first operational flight in 2004. NSB’s selection of the S-92 helicopter adds to Sikorsky’s product line operating “on top of the world,” as NSB proclaims.

North Slope Borough, Alaska, took delivery of its Sikorsky S-92 at the end of September. The aircraft will be providing search-and-rescue services for the borough, which is the northernmost municipality in the United States. **Skip Robinson Photo**





Always ready

Trusted by crews aboard the world's major airborne platforms, Goodrich rescue hoists from UTC Aerospace Systems continue to lead the way with unmatched safety and reliability.

Featuring a continuous duty cycle, our hoists are ready to perform when needed for as long as needed in mission-critical situations — providing nonstop operation where lives hang in the balance.



■ RotorBits

TOHOKU AIR SERVICE TAKES DELIVERY OF H135



Airbus Helicopters Photo

Airbus Helicopters in Japan has handed over a brand-new H135 to Tohoku Air Service (TAS). The H135 is the latest version of the EC135 family of helicopters and TAS will be the first operator to introduce this variant in Japan.

Currently, TAS is operating two EC135 P2+s, which are used mainly for power line patrols. The types of mission will expand to include aerial works, including aerial photography and survey.

"We are very pleased to introduce the new H135 variant in Japan," said Hisashi Nagahama, president of TAS. "Having been operating helicopters produced by Airbus Helicopters over the last 25 years, we are convinced that this fuel-efficient and eco-friendly aircraft is ideal to serve our missions."

PA110 PUREAIR SYSTEM RECEIVES FAA STC

Pall Corporation's PA110 PUREair System engine protection product has received a supplemental type certificate from the Federal Aviation Administration for use in Bell Helicopter's 407 and 206L families.

Featuring Pall's latest PUREair vortex tube technology, the company said the new system is self-cleaning and virtually maintenance-free.

"Our goal is to have Bell adopt the PA110 and sunset the legacy particle separator for new installations so new operators can take advantage of the new system from the factory," said Angela Hubbard, rotorcraft original equipment manufacturer sales manager for Pall.

The new PA110 system uses the latest advances in Pall Aerospace technology including 3D computational fluid dynamics optimized system design and innovative nano-material technologies. PUREair Vortex Systems enhance operations in all weather conditions, including snow, heavy rain and salt spray.

Dallas Cowboys owner receives H145



Dallas Cowboys Owner Jerry Jones arrives at The Star, the football team's headquarters and practice complex, in his new Airbus Helicopters H145 VIP helicopter. **Jay Miller Photo**

Dallas Cowboys owner, president, and general manager Jerry Jones, leader of one of the world's most recognizable professional sports franchises, has chosen a new, customized H145 corporate helicopter as his go-to business transportation tool.

The helicopter can seat eight to 10 passengers, depending on the configuration. With the new H145, Jones and his leadership team will be able to commute swiftly to and from the team's headquarters complex at The Star, in Frisco, a suburban area north of Dallas, to AT&T Stadium in Arlington for games and other functions.

"This helicopter will save us valuable time, and allow members of our organization to work and live more efficiently," said Jones.

When he took delivery of the new helicopter, Jones told Airbus Helicopters Inc. employees: "I've been so excited in anticipation of getting this helicopter. I see the quality and the pride that you put into it. It says Dallas Cowboys."

With the helicopter's ability to take off and land from nearby heliports and bypass the busy airports required by fixed-wing aircraft, the H145 will enable Jones and his management team to travel swiftly and more conveniently for business.

Airbus Helicopters Inc., based in Grand Prairie, Texas, installed the helicopter's versatile, customized interior that was designed and produced to meet the



Dallas Cowboys owner Jerry Jones, right, presents Treg Manning, vice-president of sales and marketing for Airbus Helicopters Inc., with an official Cowboys jersey. **Jay Miller Photo**

Cowboys' exact requirements.

Cabin floor carpeting and other luxury features are easily removable to allow for the helicopter's use on work trips to Jones' ranch.

"Jerry Jones made an outstanding choice when he selected the superb Airbus Helicopters H145 to be his aircraft and to be the official helicopter of the iconic Dallas Cowboys, America's Team," said Christopher Emerson, president of Airbus Helicopters Inc.

"Our company has been the leader in U.S. helicopter sales for 15 consecutive years, and that is because of the commitment of our employees to not only build and support the helicopters but to take care of each customer. We're not just selling helicopters; we're providing a gratifying long-term experience."

Stay connected to your aircraft — no matter how remote they are.

Introducing Spidertxt 2.0 — a next-generation communications tool that provides secure and reliable messaging to and from your aircraft's cockpit, anywhere in the world.



Reduced waste.



Communication.
Anywhere.



Simple.



Ops - we're airborne from the lake, 4 POB. Can you get the fuel truck ready for quick turnaround?



spidertracks

Real-time aircraft management. Made easy.

www.spidertracks.com/spidertxt

Kawak unveils new fire bucket pumps



The pump has been initially designed to integrate into 1,060-gallon and larger Bambi Buckets. **Kawak Aviation Technologies Photo**



Kawak Aviation Technologies Photo



Kawak Aviation Technologies Photo

YOUR MISSION DELIVERED







HeliTech 2016
Amsterdam, Oct 11-13
Please visit us at
exhibit stand 12F29





CNC Technologies

command & control **C2**

1 DEFINE

Define Client Mission Requirements.

2 DESIGN

Design Custom Solutions.

3 DELIVER

Deliver Commissioning, 24/7 Support, Training.

CONTACT: Alex Giuffrida 805.275.3738 mobile agiuffrida@cnctechnologies.com cnctechnologies.com

Kawak Aviation Technologies has announced a new high-capacity refill system for heavy helicopter firefighting buckets. The product was developed for operators in response to operators desiring a simplified, more reliable, and faster filling system.

Kawak said its new line of JetPump (JP) series products can fill bottom-filling buckets to capacity in streams, ponds, and tanks as shallow as 16 inches, thus allowing more flexibility in dip sites and with a fill rate that reduces cycle times.

The refill system is a derivative of Kawak's refill pump technology used in fixed-tank applications around the world.

The new line of products, called JP1150, 1600, and 2500, provide operators with a high-volume, lightweight powered fill option that can be configured with 28 volts direct current, 400 hertz, or hydraulic power options. The initial application of the new pump was designed to integrate into 1,060-gallon and larger Bambi Buckets with 27-inch valves and provide fill rates between 1,150 and 2,500 gallons (4,354 and 9,464 liters) per minute, depending upon the power source.

The modular design of the pump system requires no modification to the bucket, said Kawak. Its size is half the weight and requires only one pump instead of four, as is the case with the original refill system.

"The development of the JP series solves the current problems of mechanical issues, complexity, and reliability and as a result it allows us to provide our customers better value to pass on to their customer," said Mike Reightley, Kawak president.

"Many of our current clients are using our electric motor and hydraulic variations for tanked operations," said Reightley. "Now we can offer them a fully supported, reliable, plug and play high performance option for large buckets."



Embedded
WAAS/GPS



Touchscreen



Weather



Traffic



ADS-B In/Out
Compliance



NOTAMs
& TFRs

THE ONE FOR ALL ALL-IN-ONE ADS-B SOLUTION



L-3 Lynx NGT-9000

“A revolutionary, slam-dunk winner.”

—Flying Magazine, Editor's Choice Award



Wi-Fi Traffic & Weather
to your ForeFlight App

Thousands of pilots have found their ADS-B solution — and much more — by flying the Lynx NGT-9000. The patented and award-winning Lynx is the world's first touchscreen transponder that also displays ADS-B traffic and weather. Current promotional pricing is available online, making it even easier to own the one box wonder that is the Lynx NGT-9000.

Fly the Lynx NGT-9000 online at L-3Lynx.com



L-3Lynx.com

▪ RotorBits

GUIMBAL CABRIS
CONTINUE MIGRATION TO U.S.



Midwest Helicopters Photo

Midwest Helicopter Academy has taken delivery of another Guimbal Helicopteres Cabri G2, bringing its Cabri fleet to three in the United States to support demand within the part 141 Flight School.

“For a pilot, flight instructor and a business owner, the Cabri checked all of the boxes the S300 did for years,” said Midwest Helicopters chief pilot/owner Chris Bailey. “The G2 equals safety, efficient training, and reliability.”

The delivery brings the fleet of Cabris in the United States to 12, with plans for six additional Cabris before the end of the year. By January 2017, the U.S. will be the third largest importer of the aircraft

WAYPOINT LEASES
ASTAR TO CALQUIN
HELICOPTERS

Waypoint Leasing has closed a lease agreement with Calquin Helicopters S.A for one Airbus AS350 B3, which will transition from firefighting operations in Europe to high altitude utility missions in the Andes Mountains.

This transaction represents Waypoint’s 17th aircraft re-lease event. Since its inception in 2013, Waypoint has been active in supporting utility, firefighting and other industrial-focused helicopter operators. Waypoint’s portfolio includes more than 135 aircraft for 18 customers in 28 countries with total assets in excess of \$1.6 billion.

AVIC AC312E
TAKES TO THE SKIES

On July 27, 2016, the AC312E — a helicopter developed by the Aviation Industry Corporation of China (AVIC) — successfully completed its maiden flight in Harbin, Heilongjiang Province.

The AC312E is a light twin-engine helicopter with a maximum takeoff weight of 4,250 kilograms (9,369 pounds), with nine passengers or 600 kilograms (1,322 pounds) in cargo.

Papillon opens new Hoover Dam heliport

Papillon Grand Canyon Helicopters has opened its seventh base next to the Hoover Dam Lodge Hotel & Casino. **Mike Reyno Photo**

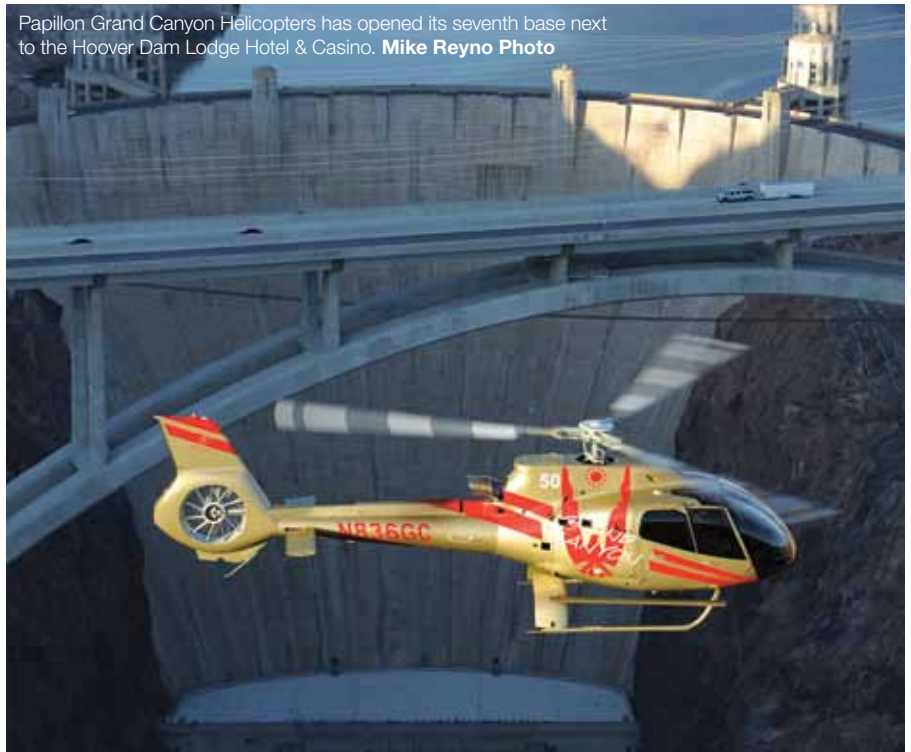

Papillon Grand Canyon Helicopters has opened a new heliport next to the Hoover Dam Lodge Hotel & Casino, and has launched new tours of the Hoover Dam area.

“The addition of our seventh helicopter base along with four new tour offerings falls in line with our long-term plan for growth,” said Geoff Edlund, president of Papillon Grand Canyon Helicopters. “We are constantly seeking new ways to appeal to our local, domestic and international visitors. With this launch we offer our guests flight options that are both affordable enough to do on a whim and compelling enough to plan in advance. A spectacular experience at an incredible value.”

To mark the occasion and celebrate the expansion of the company and its offerings, the company welcomed an international delegation of more than 100 tourism-industry VIPs and media to a ribbon-cutting ceremony on Sept. 8. With nearly 80 percent of its customer base being international visitors, Papillon invited the delegation to be the first to celebrate this milestone.

Representatives from the Boulder City



Company president Geoff Edlund cut the ribbon at a special ceremony to mark the opening of the Hoover Dam base. **Isaac Brekken Photo**

Chamber of Commerce were also in attendance, along with Councilwoman Peggy Leavitt.

Following the ribbon-cutting, the international delegation departed to experience the new Hoover Dam tours. With the new heliport, Grand Canyon Helicopters now flies guests closer to the dam and offers breathtaking views of not only the dam, but also Lake Mead and the rugged, volcanic terrain of Black Canyon.

Built to tame the once-wild running Colorado River, Hoover Dam continues to be an international attraction drawing more than one million visitors each year. From the Black Canyon side of the dam, the massive concrete structure rises 726 feet (221 meters) from the river below.



The 21st Century Helicopter

*Under \$100/hr
total operating cost*

ORDERED YOUR AEVA FLEET YET? YOUR COMPETITORS HAVE.

AEVA was designed to fly beyond line-of-sight, in controlled airspace with manned air traffic, just like helicopters. But she can also fly close to obstacles like power lines, bridges, wind turbines, and trees. 4D Artificial Intelligence (4DAI™ = Detect, Discern, Decide, Direct) onboard allows AEVA to automatically sense & avoid flight path obstacles, so she can robotically perform many of the missions helicopters do for a fraction of the operating cost.

SAFER. CHEAPER. SMARTER.

ABOUT AEVA

- Under \$100/hr total operating cost
- Built in radar/Lidar/ADS-B obstacle avoidance
- Capable of flight in all airspace – B,C,D,E, & G
- FAA type class certification underway
- Up to 10 year, 10,000 hour warranty available
- Up to 5 hour flight time carrying 11 pounds / 5Kgs
- 0-10,000 ft operation in -20F to +120F
- Completely weather sealed and IP65 rated
- 40mph wind survivable, up to 100mph sprint speeds

ABOUT OLAERIS

- Over \$85 Million in orders since HAI
- 14+ patents pending
- FAA certification underway
- Selecting exclusive dealers now



olaeris.com • +1 877 750 5500

■ RotorBits

ARGENTINA CERTIFIES HFTC SIMS



Helicopter Flight Training Center Photo

The Administración Nacional de Aviación Civil (ANAC) Argentina has certified three simulators at the Helicopter Flight Training Center (HFTC) in Shreveport, Louisiana.

ANAC inspectors certified the

HFTC's EC135 Level D full motion simulator, AS350 Level 7 flight training device, and BH407 Level 7 flight training device for Argentinian pilots, and will return in the fall to certify its EC145 Level D full motion simulator and BH407GX Level 7 flight training device.

The inspectors were required to review the training center's paperwork and fly each simulator for a minimum of two hours to grant the certification.

"Our training center is equipped with simulators for some of the most popular airframes in the industry and we want to offer them to customers worldwide," said HFTC director Terry Palmer.

JSSI EXPANDS HELICOPTER COVERAGE

Jet Support Services Inc. (JSSI) has introduced engine coverage for the new Pratt & Whitney Canada PW210S that powers the Sikorsky S-76D. JSSI is also introducing airframe parts-only coverage for the MD Explorer.

"Our plan is to provide maintenance programs for the widest cross section of aircraft in the helicopter and fixed-wing marketplace," said Neil Book, president and CEO of JSSI. "Helicopter operators deserve strong alternatives to the OEM [original equipment manufacturer] programs."

The JSSI Premium Program for the PW210S engine covers scheduled and unscheduled events, as well as life limited components and much more. JSSI Premium also offers a variety of options, including removal and replacement (R&R), off-site aircraft on ground logistical support, shipping, parts and labor for routine inspections.

Aero Design Ltd. announces Canadian certification of bicycle racks



The Quick Release Bicycle Racks allow for up to three bikes to be carried per side, and the manufacturer said the bikes can be removed and installed in less than a minute each.

Aero Design/Matthew Melsness Photo

Aero Design has announced a new addition to the Aero Design Extreme Line. The Quick Release Bicycle Racks for the Airbus AS350/355 utilize the existing Aero Design quick release mounts for its line of cargo baskets.

The company said the system allows an operator to swap from basket to bike rack in less time than it takes to perform a weight and balance amendment, and allows for three bikes per side — or any number of combinations of bike rack plus any of the four models of Aero Design Cargo Basket or two models of Aero Design Quick Release Steps for the Airbus AS350/355.

The rack will accept the shortest frame bike with a 26-inch wheel to the current longest frame mountain bike with a 29-inch wheel, all up to four inches wide and with no modification required to the rack. Additionally, Aero Design said the bikes themselves are removed or installed in less than a minute each on and off the rack.

"We knew this was something that the Western Canadian helicopter operators wanted, but we had no idea how much attention this would get from helicopter companies, cyclists as well as heli-tourism companies around the world," said Aero

Design president and Canadian M1/M2 AME Jason Rekve.

"At the time of certification we had already spoken with 22 different parties interested in bike racks throughout the globe and have been working hard to make connections so that we can all realize the mutual benefits of this and other opportunities both locally and abroad."

Jordy Norris of Blackcomb Helicopters said: "This rack is going to be a huge game-changer in a sport with incredibly powerful growth right now. We were very excited to jump in early on this project, knowing that it would bring great things for mountain biking in the Sea to Sky region and beyond. Together, we are opening up the industry to a whole new world of opportunity."

Canadian professional rider, guide and coach Lorraine Blancher said: "I don't think the bike industry yet comprehends how impactful this addition will be. Mountain bikers want adventure, they want to explore, and we now have a tool that will provide us access — even enhance trail maintenance and risk management plans — in unique and diverse areas around the globe many can't even imagine as we previously didn't have the access to search out and see."

Rhino911 using Bell 407GT to combat poachers

Rhino911, a non-profit organization established by Fred Hees, president of BBM Inc. USA, in cooperation with Heli Africa Wildlife, the operator, is to use a Bell 407GT to combat rhino poaching to curb the rising number of rhino kills in South Africa and surging demand for illegal rhino horn.

Rhino911 benefits from tactical air assets and support groups flying the specially equipped Bell 407 helicopter. Operators will find and intercept poachers of rhinos and other endangered species from extended ranges with advanced night vision and FLIR/Wescam thermal imaging and other advanced sensors. The sensors on the Bell 407GT are capable of discerning and tracking personnel from extreme distances as well as analyzing and pinpointing possible hides and entrance and exit routes poachers use, allowing timely and effective action by law enforcement authorities.

“As a South African, I wanted to make a difference and help save the rhino species from extinction,” said Hees. “Currently, a major challenge facing counter-poaching helicopter pilots is that they are not equipped with night vision and sensing systems, so they cannot operate at night and track poachers before or during the act. Our Bell 407GT

and other Bell helicopters will change this equation entirely; we are able to fly day or night, [and] isolate, track and pinpoint intruders to support anti-poaching efforts.”

Rhino911 has been in contact with the relevant government authorities in South Africa and will soon be contacting and collaborating detailed operational plans with existing rhino and anti-poaching groups, private rhino reserves, the Rhino Owners Association and key role-players in the game industry in order to ensure that all parties tackle the poachers in a holistic and controlled manner.

“Rhino911 is a fantastic initiative and we are proud that the Bell 407GT will take part in this adventure with BBM Inc.,”

said Patrick Moulay, EVP global sales at Bell Helicopter. “The advanced Bell 407 helicopters can operate far beyond the visual range of the poachers, are camouflaged, fitted with low visibility, low-noise blades and equipped with reinforced under-carriages, designed to protect the crew from hostile action.”

The Bell 407 has a Rolls-Royce M250 engine, boosting power and fuel efficiency to deliver best in class hot and high performance, perfect for the hot African climates.

Over 1,300 Bell 407s are operating around the world in a variety of missions from parapublic and emergency medical services, to search-and-rescue and corporate transport.



Bell Helicopter Photo



Bell Helicopter Photo



The specially-equipped Bell 407GT has advanced night vision and FLIR/Wescam thermal imaging and other advanced sensors to allow its crew to find rhino poachers from extreme distances. **Bell Helicopter Photo**

■ RotorBits

NATIONAL FLIGHT SERVICES EXPANDS HELICOPTER OFFERING

National Flight Services, a provider of aircraft maintenance as well as engine and component overhaul services, has announced it is expanding its offering to handle a wide range of helicopter services including avionics installations, and heavy and line maintenance.

The company provides helicopter maintenance and repair services for Airbus, Bell, Leonardo [formerly known as AgustaWestland], Robinson and Sikorsky helicopters. Services are available at its Toledo, Ohio; Lakeland, Florida; and New Braunfels, Texas locations, as well as a mobile maintenance service team that covers the continental United States.

It has also expanded its engine overhaul services and is completing hot section and overhaul services on Pratt & Whitney Canada PT6A engines.

NHV STARTS H175 OPERATIONS FOR MAERSK OIL

NHV Photo



NHV has started H175 helicopter operations in Denmark for its customer Maersk Oil, an international oil-and-gas company with whom it has a long-standing relationship.

The contract entails provision of passenger and freight transport services to Maersk Oil installations in the North Sea from Esbjerg, Denmark.

NHV will provide a dedicated crew, technicians and two Airbus H175 and H155 helicopters for the Maersk operations.

As the global launching customer of the state-of-the-art H175 model, NHV now has a fleet of eight aircraft of this type. Since their entry-into-service in December 2014, the rotorcraft have completed more than 3,000 flights and accumulated almost 5,000 flying hours in the challenging North Sea region and West Africa.

Erickson and Kestrel awarded \$24 million contract extension in Australia

Erickson Inc. and Australian partner Kestrel Aviation Ltd., have been awarded a two-year contract extension to provide wildland firefighting helicopter services in Australia.

The multi-year extension will see six S-64E Aircranes used throughout Australia to provide aerial fire suppression during the country's severe bushfire seasons. The contract is valued at \$24 million, and represents a continuation of Erickson's 20-year history of wildfire protection in Australia.

Under the agreement, Kestrel and Erickson will provide S-64s at up to six different locations throughout Australia for rapid response to threatening bushfires during the October to March fire season.

"We have been contracted through Kestrel Aviation to the National Aerial Firefighting Center for the past three years with six Aircranes, and the state fire

agencies in Australia have been very pleased with our performance," said Andy Mills, vice president of global business development at Erickson. "This is an important continuation of our firefighting operations throughout Australia; it is a mission we are proud to perform and one we take very seriously on behalf of the citizens of Australia."

The Erickson S-64 Airplane can lift up to 10 tons of water, and is currently used to perform firefighting missions in five countries around the globe.

"Erickson has more than 20 years of firefighting experience in Australia and our crews and pilots — as well as the company as a whole — take a great deal of pride in the special relationship we share with the Australian leadership and community," said Rob Lewis, vice president of Erickson's civil business. "We appreciate their vote of confidence."

Mecaer validates additional AW139 FAA STCs

Mecaer Aviation Group (MAG) has validated additional supplemental type certificates (STCs) with the Federal Aviation Administration (FAA) for the AW139 in VIP configuration. The STCs were previously validated with the European Aviation Safety Agency.

MAG said it responded to the growing demand for additional options in the United States for VIP-configured AW139s containing a higher level of technology while reducing noise levels in the cabin. MAG has customized nearly 200 VIP AW139s around the world, predominately in Europe.

The new STCs with the FAA will assist in a more even distribution of interiors by MAG, the company said.

The two additional STCs provide combinations for more than eight different layouts and configurations. VIP seating

arrangements range from four seats with multiple cabinets and consoles to eight-seat configurations.

In addition, the layouts are interchangeable, allowing executive flight departments to quickly change between configurations.

MAG's proprietary technologies, including speech interference level enhanced noise system (SILENS) and I-FEEL (In-Flight Entertainment Enhanced Lounge), are options in all of the new STCs. MAG's SILENS provides a low-noise interior, while I-FEEL provides passengers with customizable infotainment.

"We are listening to our U.S. clients," said Armando Sassoli, co-general manager of Mecaer Aviation Group. "The market in the U.S. and specifically the operators near our Philadelphia facility wanted a quieter and lighter weight option — we have responded." 

If you would like to submit a press release or if you have a new product or service that you believe is newsworthy, please e-mail our news editor at news@verticalmag.com.



THIS IS **HUGE**

The world's best helicopter website has gotten even better.
More amazing content. Brilliant design. An immersive reader experience.
The results will blow you away.



loads
2X FASTER
globally



exceptional
MOBILE
experience



enhanced
SEARCH
capability



totally
SECURE
browsing

THE NEW
VERTICALMAG.COM

Interviewed by Oliver Johnson



John Hyde has served as the exhibition director of Helitech International — Europe's largest helicopter exhibition — since 2011. The show has alternated location between London, England, and Amsterdam, the Netherlands, for the last four years, and will return to the RAI Amsterdam from Oct. 11 to 13 in 2016.

VERTICAL: HOW ARE PLANS FOR AMSTERDAM COMING ALONG?

JOHN HYDE: Really well! This is our second trip over to Amsterdam. We were first over there in 2014, and it's all going really well.

V: WHAT DROVE THE DECISION FOUR YEARS AGO TO CHANGE THE FORMAT FOR HELITECH?

J.H.: Helitech used to run on a biannual basis in Duxford in Cambridgeshire. It was predominantly U.K.-focused, U.K.-based, and most of the exhibitors and visitors were from the U.K. We started working with the European Helicopter Association back in 2011 and they wanted — in conjunction with the major manufacturers — to see Helitech become more of an international event and attract a wider international audience. The manufacturers wanted a platform to showcase their latest products in Europe rather than always going across to Heli-Expo and the U.S. They always will go to that show because the market size in the U.S. dictates that they do and that is the major show, but they wanted a more international and professional platform within Europe.

Duxford was held in temporary structures in the U.K. countryside, so it was subject to the weather we have over here. You had all sorts of problems with it being too hot with no air conditioning, or it being too wet with muddy fields and the tem-

John Hyde

porary structures collapsing because of the weight of the water on them. We were given some really clear criteria from the major manufacturers — they wanted a city center location, really good networking opportunities, good facilities around wherever it's located, and world class exhibition halls, with the ability to fly in and fly out. Most important was international transport links, because they wanted to drive the international visitor and exhibitor base. Hence London, because of the major airports around London, and crucially Amsterdam as well — because we looked at a number of different locations in Europe, and Amsterdam Schiphol is the fourth largest international hub in Europe. It's also a great city to go out in, so it ticked the networking box, and it's a well-located venue near the center of town.

Also, with a rotorcraft event, when you want to fly aircraft in and out, you have to have the full support of the locals — the government, local council, air traffic control, the nearby airport — and we have that in Amsterdam.

V: HOW HAS IT CHANGED OVER THE FOUR YEARS?

J.H.: We created the U.S. pavilion in 2014 to showcase U.S. exhibitors, and that's been a big success. We've gone from around 30 U.S. exhibitors to around 50/55. The overall percentage of non-U.K. visitors has grown, as well as our total audience numbers. We had visitors from 65 countries coming to the show in London in 2015. A third of our visitor audience doesn't go to any other rotorcraft event, which is quite interesting. Bringing it over to Amsterdam has opened it up to other European countries, so we've seen more operators attending from the rest of Europe — particularly Eastern Europe, which is an important market.

V: WHAT CAN WE EXPECT FROM THE SHOW IN 2016?

J.H.: The seminar and workshop program is being revised this year. We've listened to the feedback we've had from operators in particular, and what they want us to deliver is shorter, sharper, more focused sessions, and some insight sessions to help them understand what

business opportunities there are there for them. The safety workshop and business leaders forum will be crucially important this year, and those are the sessions that people do come and sit in and actively take part. So keep an eye on the website for who's speaking and what the subjects are.

New for 2016 are the technical briefings. One of the bits of feedback we got from our operators was that the show is great, but they want more technical information on the latest products that are being launched — they want to be able to make informed buying decisions while they're there. So this year, the manufacturers and OEMs will be running their own technical briefings on the latest products that will be on the show floor. It's a really good interactive session for technicians and engineers to learn how these products work and how they're relevant to their business.

V: YOU'VE OBVIOUSLY BEEN SPEAKING WITH INDUSTRY MEMBERS TO PREPARE FOR THE SHOW — HOW ARE THEY FEELING ABOUT THE INDUSTRY RIGHT NOW?

J.H.: It depends what part of the market you're from. Our key target audience for the visitor side is operators. We want to drive more operators to come from all over the globe into this event from all the vertical market sectors, so we've done a lot of research with them.

First and foremost, they want to know how they can expand their businesses. A lot of the operators that we talk to are, as we all are, quite time poor, so we have to really give them tangible reasons to spend two days out of the office, when they could and should be doing other things.

Quite topical at the moment is how the downturn in the oil-and-gas sector is affecting new aircraft sales and also aircraft values. That's come back a lot in the research we've done. Another issue is attracting the right people into the industry — the right level of pilots and mechanics with the right experience for some of the more complex missions.

But, while the oil-and-gas market might be down, helicopter emergency medical services [HEMS] market opportunities

are being created. So we're focusing quite a lot of the content in our seminars and workshops on the HEMS market — delivering new business opportunities and covering some of the new trends for emergency medicine. We're working quite closely with key players in the European medical industry to have think-tank sessions at the show and work out how the two industries can work in unison to create opportunities.

Some of the key things that have come back time and time again are what future regulation/legislation is going to look like, because there's been huge change in Europe with the shift from national civil aviation control to EASA control, so we work very closely with the European Helicopter Association and actually have a session with EASA to talk about some of the future regulation that will be affecting the market.

V: ARE YOU SEEING ANY OPTIMISM FROM THE PEOPLE YOU'RE CHATTING TO?

J.H.: Yes, definitely from the HEMS community — there's a fleet replacement going on at the moment, and a lot of working smarter. I think one of the elephants in the room that seems to come back time and time again is the UAV/drone side of things. Is that an opportunity or a challenge? We've taken the stance in the last two years in our conference that it's actually a business opportunity. There are some very smart companies out there incorporating this technology into their existing business model and making a success of it. One example I can think of is the Dutch Coast Guard — rather than sending out the aircraft and crew for hours at a time looking for whatever they're looking for offshore, they send the drone out, it spots where the person or situation is, and then they send the crew to sort the problem out. So it's a matter of working smarter and more effectively.

V: IS IT A CHALLENGE TO CONVINCE PEOPLE OF THE VALUE OF TRADE SHOWS IN THE CURRENT ECONOMIC CLIMATE?

J.H.: I think to say that that's not a challenge would be untruthful. It will always be a challenge to get people away from their workplace, not just in the rotorcraft industry, but any event in any industry. It's why we make sure what we are presenting is key to the market we're addressing, that the issues that will be discussed there are of crucial importance to whether

their businesses are successful or not. Once they understand that, then that's the motivation to attend. But a huge factor as well is the networking side of things. People have worked in this industry for a long time, they've got a lot of good connections, so we try to create as many networking opportunities for those companies as we can, whether they're exhibiting or a visitor.

V: WHAT IMPACT DO YOU THINK BREXIT WILL HAVE ON THE EUROPEAN INDUSTRY?

J.H.: From what I've heard, very little at the moment. Because it hasn't actually happened. It's all speculation. It wasn't very long ago that the referendum took place. In terms of the next two years, there's a little bit of uncertainty about what will happen, but we're a global rotorcraft community, we operate globally, the show is an international event. "Steady as she goes" is the message from our point of view. ✦

This interview has been edited and condensed.



**EXPERTS IN
LIGHT HELICOPTER SIMULATION**

FRASCA provides helicopter simulation products for a wide range of rotary wing aircraft with expertise and experience in light helicopters including the R44, Bell 206, AS350/H125, and others. New technology including our SimAssist™ and Motion Cueing System add to the value and realism you want and need in a flight training device.

Contact us to find out how a FRASCA simulator can optimize your flight training program.

217.344.9200 • info@frasca.com
www.frasca.com

FRASCA
FLIGHT SIMULATION

A Sky-Futures unmanned aerial vehicle (UAV) deployment team member releases an aircraft off the helipad of an offshore platform. The company uses a variety of UAVs for different work, but its current offshore UAV is the AscTec Falcon 8. **Sky-Futures Photo**



As the helicopter industry continues to adapt to the challenges faced in the oil-and-gas sector, two long-established operators have added unmanned aerial vehicle (UAV) services to their portfolios. And rather than starting from the ground up, both operators have partnered with experienced unmanned aircraft system (UAS) companies.

Bristow Group entered the UAS sector earlier this year, with a \$4.2 million investment in U.K.-based Sky-Futures. Operating in over 21 countries, Sky-Futures has provided UAS services for the oil-and-gas sector since 2011. “The oil-and-gas market is global and significant,” said James Harrison, Sky-Futures co-founder and CEO. “Everywhere there is oil-and-gas infrastructure, there is a requirement for UAVs.”

Michael Shaffer, director of corporate development and strategy at Bristow, said the Houston-based company’s investment in Sky-Futures gave it immediate entry to the fast-growing UAV commercial space. “The two companies are working together to leverage each other’s strengths to offer cost-efficient solutions to mutual customers,” he said. “Bristow has been taking proactive steps to differentiate its existing aviation offering and capitalize on opportunities to provide complementary services that are a natural extension of our aviation expertise. We see unmanned aerial vehicles playing a substantial role in the future of aviation.”

Era Helicopters has been in operation for almost 70 years, and sees UAVs as a natural extension of its aviation services. “We have monitored the introduction and development of unmanned aerial vehicles and their commercial applications for some time,” explained Paul White, Era’s senior vice president of commercial. “UAVs have been utilized by our clients across a variety of industries for a few years now. Era verified the potential efficiencies and safety enhancements offered through the experienced use of UAVs, permitting us to further extend our

REMOTELY POWERED

How oil-and-gas operating giants Bristow and Era Helicopters are incorporating unmanned systems into their fleets.

By Howard Slutsken

mission to enhance [the] safety, efficiency and reliability of our customer offering.”

In August, Era entered into an exclusive agreement with Total Safety, a worldwide provider of safety and compliance services. “Era will be managing the UAV flight operations while Total Safety will provide the sensory subject matter expertise and inspectors,” said White. “The collaboration represents the opportunity to build off of each other’s existing relationships and provide an unparalleled service offering.”

FINDING A UAV NICHE

In terms of operational utility in the oil-and-gas segment, UAVs are used to perform inspections of offshore rigs and platforms, providing HD video, stills, and thermal imagery for analysis. A UAV team can be tasked with underdeck inspections, topside work, decommissioning, and splash zone and emergency inspections. But the UAV really comes into its own for active flare inspections, a process that used to be difficult, risky, and expensive.

With discharge temperatures above 1,000 C (1,800 F), flare stacks could previously only be safely inspected from adjoining structures or from a helicopter, or by taking the expensive operational option of bypassing the system. Now, instead of taking a flare stack offline, a UAV can inspect a live stack to determine whether the flare is operating properly, and to evaluate whether maintenance or replacement is required.

“We inspect hard to access areas such as flare stacks, heat shields, and other areas that cannot typically be inspected during production,” said Sky-Futures’ Harrison. “This means that we can bring significant operational savings of around \$7 million per day by avoiding shutdowns offshore. The biggest advantage is the cost alone

— it’s around 85 percent more cost effective to use UAVs for multiple scopes of work offshore than rope access technicians.”

“We did a case study in the U.K. North Sea, and our team completed five days of work that a rope access team would have scheduled eight weeks to complete. We also inspect confined spaces using a UAV without having a human enter the space itself — a huge safety improvement. In fact, B&W Offshore [a global provider of floating production, storage, and offloading vessels] called this increased safety ‘invaluable,’” he said.

There isn’t one single UAS solution that will work for all clients, according to Era’s White. “Each job is different, potentially requiring multiple planning and data collection days, a variety of sensors, and potentially multiple rotor-wing and fixed-wing UAS. There really is no ‘stock’ job given the wide variety of applications and varying client requests,” he said. “Era utilizes UAVs that have outstanding endurance, payload capabilities and triple redundant autopilots, and operate very well in GPS-denied environments.”

White also believes that it’s important to recognize that UAVs aren’t a stand-alone solution, but another resource to be deployed for the right projects. “UAVs do not replace the need for human inspection; they are merely a complementary tool for surveyors and inspectors to utilize. The UAVs are the delivery systems for the sensor technology, and the value to the client is in the efficient collection and delivery of data, which leads to better decisions and outcomes.”

Bristow’s Shaffer shares this opinion. “Although UAVs do not completely replace traditional methods of inspection, they can enhance or provide a better alternative solution that is safer, faster and more cost-effective for the client. UAV inspections on industrial infrastructure enhance planning, may be completed without disrupting production

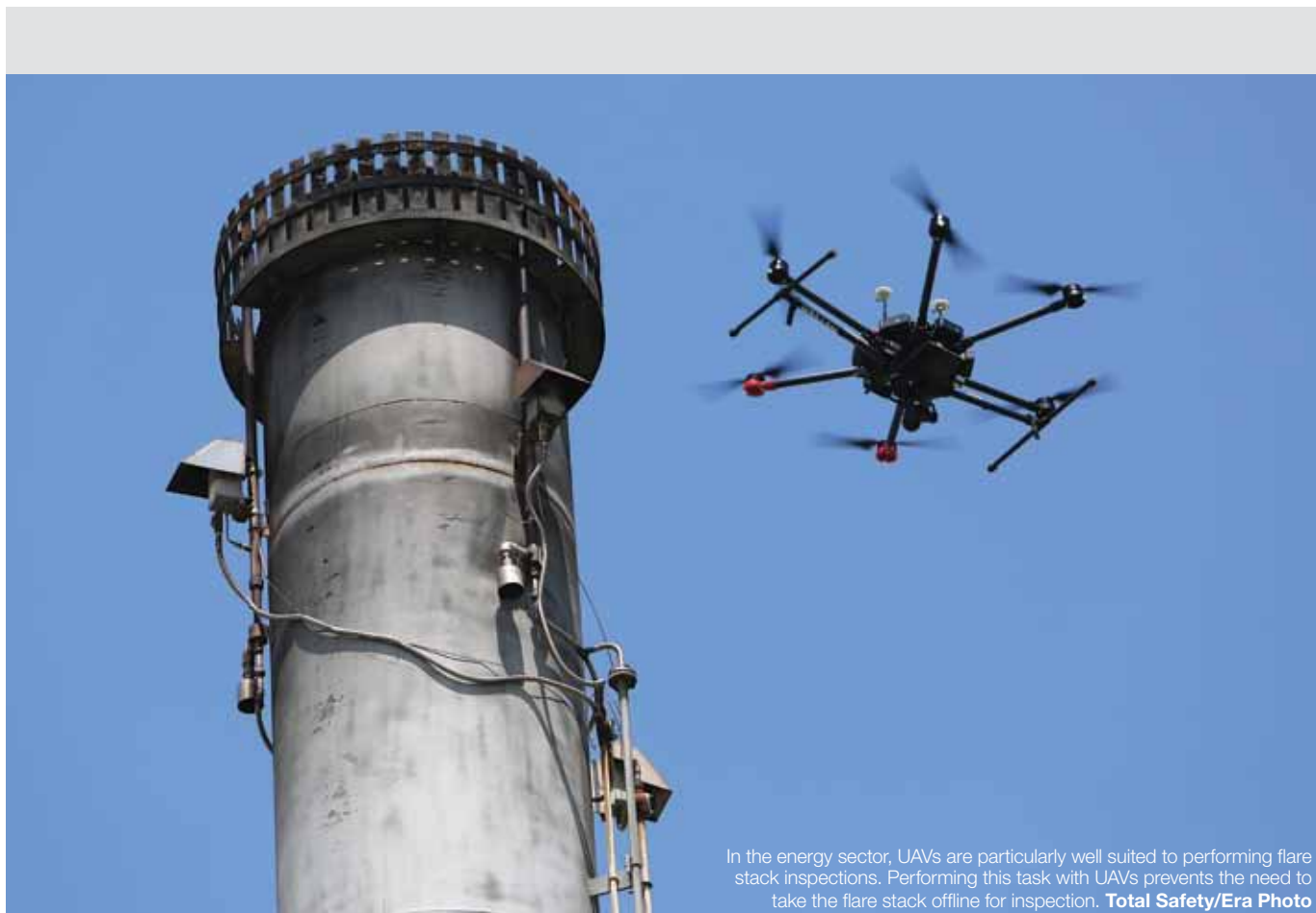

In the energy sector, UAVs are particularly well suited to performing flare stack inspections. Performing this task with UAVs prevents the need to take the flare stack offline for inspection. **Total Safety/Era Photo**

and can eliminate the need for costly and potentially unnecessary shutdowns,” he said.

WHAT’S IN A UAV DEPLOYMENT?

When performing a rig inspection, Sky-Futures deploys a UAS kit with a small and easily-fielded team made up of a remote pilot and a certified inspector/sensor operator. “We use a variety of UAVs for different work, but our current offshore UAV is the [AscTec] Falcon 8,” said Sky-Futures’ Harrison. “We fly in sorties of approximately 10 minutes and the length of time depends on the scope of the job required. A flare stack can be inspected in half a day, and our average job is five days long.”

For Era’s UAVs and related equipment, White explained that the kit is packed into hardback cases and is transported in the company’s mobile command vehicle, or if necessary, by air or ship.

“The batteries are sized to meet commercial flight requirements and are maintained through a robust battery management program that meets all rules and regulations,” said White. “In general, I would say jobs require between two to four pilots, sensor techs, and support personnel depending on applicable local laws and customer-driven rules and regulation. This does not include the back end data management and client deliverables.”

But it’s still early days for the use of UAVs in this sector, explained Sky-Futures’ Harrison. “New sensors will enable a huge new market to open up within oil-and-gas,” he said. “We are already able to measure the size of defects to plus or minus one millimeter using proprietary laser measurement technology, and the data can be further analyzed. Our view is that the market for UAVs will be driven by strong business cases; one of which is the ability for more end users to be able to view the latest data from offshore or from a confined space without physically looking at a report.”

Sky-Futures’ “Hangar” software fuses real-time UAV data and associated captured metadata into 3D models and reports that are accessible via a secure cloud-based online portal. “We believe this software will help to drive the market for UAV data, as more and more end users can derive information that could not previously be captured, such as tracking defect size over time and using the derived imperial data from Hangar to do predictive analysis,” said Harrison.

“There really is a tremendous opportunity in this space,” said Era’s White. “As you know, we have served the oil-and-gas sector for decades, so we are pretty well read into their needs from an aviation perspective. Our clients are coming to us with potential use cases all the time. In many cases, multiple business units inside the same organization are utilizing UAVs to collect and interpret data related to infrastructure, supply chains, regulatory compliance, general security and other very exciting areas. Again, the technology is moving so quickly that it seems every day UAVs become a more important data collection tool. It’s a very exciting time to be in this business.”

However, UAVs won’t be replacing helicopters, stressed White, citing the evolution in aerial electronic news gathering (ENG). “You can now dispatch a helicopter to get the initial shots in real time, and then take the follow up shots from a UAS. This delivers substantial cost savings to the client and can also be much safer in poor weather or high density areas,” he said. “We don’t see UAVs as a threat to rotary services, but as a complementary tool.”



IT'S SIMPLE MATH.

AIRWOLF

= INNOVATION

Longer life, lower cost TT Straps, and other life limited components.

Thanks you

AIRWOLF

for helping us
CHANGE THE INDUSTRY

- Enstrom 480 36 month TT Straps & conversion kits for Enstrom Piston Helicopters
- Bell Jet Ranger, Long Ranger & OH-58 (36 Month)
- Bell 204, 205, 212, UH-1 & AH-1,
- NEW: 36 Month TT Straps

COMING SOON: Strap Fittings, Pins, Latch Bolts and other Life Limited Components

ALWAYS IN STOCK

440-632-1687

www.airwolfaerospace.com

See us at HAC
Booth #404

Howard Slutsken | Howard Slutsken's lifelong passion for aviation began when he was a kid, watching TCA Super Connies, Viscounts, and early jets at Montreal's Dorval Airport. He's a pilot who loves to fly gliders and pretty much anything else with wings. Howard is based in Vancouver, B.C.



FOCUSED ON YOU*



*Le client au cœur de nos projets - Coordinateur/Responsable: Fern-Larocq's Agency - ©Jiffy Images



EXTEX ENGINEERED PRODUCTS

Part #: E500N5215



FAA Certified Main Driveshaft For The MD500 Series

- Designed and Manufactured of the Highest Quality
- Integral Fail-Safe Design
- Lower Cost of Ownership
- In Stock for Immediate Delivery

EXTEX Engineered Products now holds FAA PMA on a replacement for the MD500 Main Driveshaft. For information on price and availability, contact EXTEX at (480) 632-1039.



www.extengineered.com

KAMAN
Specialty Bearings &
Engineered Products

UNDETERMINED REASONS



More than 20 years after the U.S. National Transportation Safety Board launched a special investigation into loss of main rotor control accidents in Robinson helicopters, fatal in-flight breakups continue to happen — and we can't fully explain why.

By Elan Head

On June 29, 1992, a flight instructor and his pre-solo student took to the air in a Robinson R22 helicopter over northern California's San Francisco Bay Area. The instructor was relatively experienced, with about 2,000 hours of R22 flight time. The student had only four hours of flight time, all in the R22. She had brought along a microcassette voice recorder, which was set up to tape the cockpit and radio communications during her lesson.

The helicopter's low rotor r.p.m. warning horn was checked on the ground before takeoff; it operated normally. And nothing appeared to be out of the ordinary during the 17-minute flight to a local practice area near Richmond, where the student, at the instructor's request, executed a shallow left turn.

The U.S. National Transportation Safety Board (NTSB) described what happened next: "Seconds later, while cruising at 2,200 feet, the CFI [certified flight instructor] began talking. In mid-sentence an undetermined event occurred which interrupted his speech. A wind-like background noise started, and the student exclaimed, 'Help.'"

Radar data confirmed witness reports that the helicopter's tail boom and main rotor had separated in level flight. The aircraft plunged into the San Pablo Bay, killing the instructor and student. Examination of the wreckage revealed that the aircraft had experienced "mast bumping" — severe contact of the rotor hubs with the mast, a phenomenon that is often associated with low-G maneuvering. The main rotor blades had diverged to strike the tail boom, which can occur as a result of mast bumping or low r.p.m., leading to rotor stall.



Download as wallpaper at verticalmag.com/wallpaper

Recent accident reports out of New Zealand have raised new questions about the causes of mast bumping accidents in Robinson helicopters — and the best ways to prevent them. **Mike Reyno Photo**



Robinson R22, R44, and R66 helicopters have accumulated over 30 million flight hours in all types of operating conditions, and loss of main rotor control accidents are relatively rare. However, the mysterious and catastrophic nature of these accidents has led to them receiving special attention from accident investigators over the years. **Mike Reyno Photo**



Before the Richmond crash, 23 other Robinson R22s had experienced similar losses of main rotor control — events which are almost always fatal and, in the absence of recording devices, leave few clues as to their causes. Investigators trying to piece together circumstances after the fact had chalked up many of these accidents to low-G maneuvering or low rotor r.p.m., implying mishandling by the pilot.

But the recorded evidence in the Richmond crash simply didn't support the usual explanations. Neither pilot had voiced any concern about the operation of the helicopter before the breakup. The low r.p.m. warning horn didn't activate before or during the breakup sequence, and spectral analysis of the audiotape indicated that the aircraft was being operated at a normal main rotor r.p.m. Radar data showed that the airspeed was normal for cruise flight, and there was nothing to suggest low-G maneuvering.

With no easy way to explain the Richmond crash, the NTSB launched a special investigation into R22 loss of main rotor control accidents. Meanwhile, the U.S. Federal Aviation Administration (FAA), which had already conducted two special certification reviews of the R22, initiated a third. It also convened a technical panel to study R22 loss of main rotor control accidents, and commissioned the Georgia Institute of Technology (Georgia Tech) to conduct simulation studies of the R22 main rotor system.

In addition to several airworthiness directives and bulletins, in February 1995, the FAA issued Special Federal Aviation Regulation (SFAR) 73, which created specific training and proficiency requirements for Robinson R22 and R44 helicopters. When the NTSB issued its own special investigation report the following year, it was still unable to explain the Richmond crash and many similar accidents, but it was encouraged by the fact that no loss of main rotor control accidents had occurred since the SFAR was enacted.

"Although the Safety Board cannot conclude that the operational changes will eliminate all in-flight rotor strikes, the absence of such accidents since these actions were implemented suggests that they have been effective," the NTSB wrote. "The absence of such accidents also supports the proposition that most of the accidents were caused by large, abrupt control inputs and the corrective actions taken should help prevent such accidents."

Since SFAR 73 was enacted, Robinson loss of main rotor control accidents have occurred less frequently in the U.S., but they haven't stopped entirely. And in at least one country, New Zealand, they have continued to occur at a high rate, with New Zealand's Transport Accident Investigation Commission (TAIC) citing at least 12 such accidents or incidents since 1996, despite the relatively low total number of Robinson helicopters in the country.

In a very small number of these accidents, there is eyewitness testimony or other direct evidence to suggest improper handling by the pilot. But in most cases, investigators are no closer to being able to explain these accidents than they were 20 years ago. For almost all of

them, the probable cause statements are essentially the same: "the divergence of the main rotor from its normal plane of rotation for an undetermined reason."

'MAST BUMPING IS REAL'

Robinson Helicopter Company is not the first helicopter manufacturer to struggle with the problem of mast bumping. The potential for mast bumping is inherent in all two-bladed helicopter main rotor systems, which teeter like a seesaw around a central rotor mast. The main rotor blades on all helicopters flap up and down as a way of equalizing lift throughout their plane of rotation, but in models with more than two blades, each blade flaps individually at the same distance from the mast.

In two-bladed, so-called "semi-rigid" rotor systems, when one blade flaps up, the other flaps down. The root of the down-flapping rotor blade moves closer to the rotor mast, and may contact and damage the mast if the separation between them is further reduced. When mast bumping occurs in flight, it is almost always catastrophic. Flapping becomes so severe that a blade may slice through the tail boom or cabin. The rotor mast may be completely severed, resulting in the entire rotor system detaching from the aircraft.

Pilots of two-bladed helicopters can induce mast bumping through low-G maneuvering. A cyclic pushover after a climb — such as might occur if a pilot is flying low over hilly terrain — can momentarily unload the weight of the fuselage from the rotor disc. The thrust from the tail rotor above the aircraft's longitudinal center of gravity may then induce a rapid roll of the fuselage (to the right, in Robinson helicopters). If the pilot instinctively applies cyclic in the opposite direction to counter the roll, the still-unloaded rotor system will tilt excessively relative to the rotor mast, resulting in mast bumping.

Turbulence can also lead to low-G situations and abrupt control inputs, increasing the risk of excessive blade flapping and mast bumping. The risk is greater at higher airspeeds, which is one of the reasons why pilots are instructed to slow down when they expect or encounter turbulence.

Mast bumping was first identified as a significant issue by the U.S. Army in the early 1970s, following a number of fatal crashes of Bell UH-1 Huey and AH-1 Cobra helicopters in which the main rotor system separated from the aircraft in flight. (Notably, the Bell OH-58 Kiowa never experienced the same problems, and the rate of mast bumping accidents in Bell civil helicopters has also been very low.)

A simulation study conducted by Bell Helicopter in 1975 and 1976 confirmed that excessive main rotor blade flapping could occur "at center of gravity extremes, under low or negative-G conditions, with large abrupt control inputs, and in conditions of significant retreating blade stall." Accordingly, early training material emphasized the importance of pilots operating within "recommended flight envelopes" and avoiding low-G conditions.



In most cases, investigators are no closer to being able to explain these accidents than they were 20 years ago.



The U.S. Army experienced a number of fatal mast bumping accidents in its Bell AH-1 Cobras and UH-1 Hueys beginning in the 1960s. The Army initially sought to address the problem through pilot education, although Bell eventually designed a hub spring to reduce the risk of mast bumping. **Skip Robinson Photo**

A 1974 article in *U.S. Army Aviation Digest* warned, “Mast bumping is real; it can occur if we operate teetering rotors incorrectly; and it must be prevented. The lesson to be learned from this discussion is this: operate your aircraft within its design envelope.”

A U.S. Army training film developed in the late 1970s stressed, “The basic lesson here, and the single most important message that should have come through, is that you as a pilot can prevent mast bumping by the way you handle the aircraft.”

According to a 1983 article in *U.S. Army Aviation Digest*, mast bumping was associated with 59 accidents and 213 fatalities in U.S. Army UH-1 and AH-1 aircraft between 1967 and 1982. However, in 42 percent of these cases, the initial step in the accident sequence was some kind of mechanical failure, such as tail rotor failure. Weather or turbulence was implicated in 17 percent of the crashes, while only 10 percent were directly linked to low-G maneuvers or crew error. In 29 percent of the cases, the initial step in the accident sequence was “unknown.”

The Army contracted Bell to explore design solutions to the problem, and Bell had developed a retrofittable hub spring to reduce the risk of mast bumping by the late 1970s. But with new-generation utility and attack helicopters on the horizon, the Army chose not to buy the hub spring. Instead, the emphasis remained on training pilots to avoid flight outside the approved envelope, even though the 1983 *Army Aviation Digest* article pointed out that “operating conditions that are *within* the approved envelope may cause high flapping and mast bumping depending on the individual pilot’s reaction to certain situations.”

Several months after that article appeared, an extraordinary accident involving an AH-1S Cobra at the U.S. Naval Test Pilot School in Patuxent River, Maryland, raised new questions about the possibility of experiencing mast bumping within the approved flight envelope. According to an account published by the reporter Mark Thompson in the *Fort Worth Star-Telegram* in 1984, an instructor pilot at the school, Major Larry B. Higgins, was training Major James M. O’Brien

on use of the Cobra’s pedals when O’Brien, who was in the rear seat, input more pedal than expected. The aircraft immediately rolled right and entered a dive. A main rotor blade smashed through the cockpit, instantly killing O’Brien and flinging Higgins into the air.

Because he was wearing a parachute in accordance with school protocol, Higgins survived. Based on his testimony, Navy accident investigators concluded that the pedal input was well within allowable limits, and that “there are possible unknown factors that may cause mast bumping to occur in flight regimes under which a pilot would not normally expect this phenomenon to occur.”

Bell disputed both Higgins’ testimony and the Navy’s conclusion. However, the attention associated with the case — and a lawsuit brought by the widows of pilots killed in an earlier mast-bumping accident — prompted the Army to make some modifications to its Bell Helicopters. Eventually, it moved away from two-bladed rotor systems altogether. Today, the Huey and Cobra live on in the U.S. military’s inventory as the UH-1Y Venom and the AH-1Z Viper, respectively, but these modern variants have main rotor systems with four blades, not two.

AN ‘EMERGING ACCIDENT TREND’

The U.S. Army may have largely eliminated its mast bumping problems, but the training film it created on the subject endures. When I began my primary helicopter flight training in the Robinson R22 in late 2004 — nearly a decade after the enactment of SFAR 73 — I dutifully sat through the U.S. Army Safety Center’s *Mast Bumping: Causes and Prevention* as part of my required education on mast bumping and low-G hazards.

“It may be necessary to view the film more than once,” its narrators told me, and by the time I became a certified flight instructor in Robinsons, I had. I taught my students what I had been taught — that mast bumping will not occur in the absence of an incorrect action by the pilot. As the film had drilled into me, “*you* as a pilot can prevent

NOBODY STABILIZES YOUR HELICOPTER MAINTENANCE COSTS LIKE JSSI.

Only Jet Support Services, Inc. gives you all the service and protection the OEM programs provide, plus advantages they can't. Like JSSI's exclusive Tip-To-Tail® coverage and 24/7 access to the largest Technical and Client Services Teams around the world. You'll even have the freedom to transfer your program to virtually any make or model of aircraft. Want to learn more? Call us.

jetsupport.com • communication@jetsupport.com • +1 312 644 8810 • +44 1252 52 6588



JSSI



Kurt Robinson said his company has no objections to further modeling and simulation efforts to understand mast bumping — but emphasized that Robinson Helicopter Company has found no indication of main rotor divergence within the helicopters' normal operating envelope over many years of flight tests. **Skip Robinson Photo**





New Zealand's Transport Accident Investigation Commission has recommended that the FAA extend the knowledge and training requirements of SFAR 73 — currently applicable to the Robinson R22 and R44 — to the R66 Turbine helicopter. **Skip Robinson Photo**

most bumping by the way *you* handle the aircraft.”

By the time I started my flight training, demonstrations of low-G recoveries in Robinson helicopters had been prohibited in the U.S. However, the film also drilled into me the official recovery technique for a low-G right roll: first aft cyclic to reload the rotor disc, and only then left cyclic to correct the roll. I recited this mantra on my stage checks and checkrides, and my students recited it on theirs.

After accumulating around 1,200 flight hours in Robinson and Bell helicopters with two-bladed main rotor systems, I assumed that mast bumping was a well understood, relatively noncontroversial phenomenon. So I was surprised to learn, earlier this year, that New Zealand's Transport Accident Investigation Commission holds a somewhat different view.

In May, the TAIC released its final report on a fatal R66 crash that occurred in the Kaweka Range of New Zealand's North Island on March 9, 2013. The helicopter was being used to ferry hunters and fishermen to and from remote sites in the mountains when it experienced mast bumping and broke apart in flight, killing the pilot, who was the only person on board at the time.

The TAIC determined that “the mast bump very likely occurred when the helicopter encountered moderate or greater turbulence, which likely resulted in a condition of low G.” The helicopter was calculated to have been within its weight and center of gravity limits, although at 756 kilograms (1,667 pounds), it was on the light side of the allowable range of 635 to 1,225 kg (1,400 to 2,700 lbs.). Likewise, while its estimated airspeed of 115 knots, as calculated from satellite tracking data, was below the never-exceed speed of 123 knots for the prevailing density altitude, it was much faster than the 60 to 70 knots that

Robinson recommends in conditions of “significant” turbulence. Both the light weight and high airspeed would have “exacerbated” the effect of any turbulence, the commission noted.

The TAIC acknowledged that “the possibility that an intentional or inadvertent control input by the pilot contributed to the mast bump cannot be excluded.” But it also identified some additional safety issues related to the aircraft's certification.

Like the R22 and R44, the R66 has a main rotor system that differs from other semi-rigid rotor systems in that it incorporates coning hinges for each blade, as well as a central teeter hinge. The R66 certification program took advantage of these similarities; for example, the FAA accepted the results of an earlier R44 rotor flapping survey as evidence that the R66 met the certification blade clearance requirement.

However, the TAIC called attention to the fact that the R66 certification program “was not required to test the helicopter's response to low G, in spite of low G being known to present a serious risk of mast bump for the R22 and R44.” And the FAA's Flight Standardization Board specifically declined to apply the training requirements of SFAR 73 to the R66, declaring that “the R66 performance and flight characteristics were typical and unremarkable compared to other part 27 helicopters of similar rotor design, therefore the R66 does not require specific training for unique flight characteristics.”

In May 2014, about a year after the Kaweka crash, Robinson did finally conduct an R66 main rotor flapping angle survey, testing push-over maneuvers to a minimum G of +0.33 (in each case, the test pilot initiated recovery action as soon as the anticipated roll began). According to the TAIC, “the survey showed that the R66 responds to low G in the same way as the R22 and the R44.”

The TAIC expressed the concern that because the R66 was certified without any special training requirements, pilots with no previous Robinson experience might start flying the R66 without fully appreciating the hazards of low G. Meanwhile, pilots familiar with the R22 or R44 — including the pilot in the Kaweka crash — “could infer from the lack of any special training for the R66 that the R66 does not require the same careful handling as the smaller types.”

In fact, the TAIC argued, “the emerging accident trend and instructional experience to date suggest that the R66 does require the same careful handling.” The commission’s report pointed out that three of the seven fatal accidents that had occurred in the R66 to date had involved an in-flight breakup and main rotor separation. (Another accident that occurred during unauthorized flight instruction in Colombia was due to low r.p.m. rotor stall, which is also an SFAR 73 training requirement.) In June of this year, another fatal R66 crash occurred near Wikieup, Arizona; the NTSB’s preliminary report for that accident also suggests an in-flight breakup.

The TAIC recommended to the FAA that it extend the knowledge and training requirements of SFAR 73 to pilots of the R66 helicopter (at the time of this writing, the FAA was still composing its official response). But the commission made another recommendation, too — that the FAA “reinstate research into the dynamic behavior of two-bladed, teetering, underslung rotor systems.” Because while I was taught, and many people still maintain, that mast bumping can only occur a result of mechanical failure or improper handling by the pilot, the TAIC is not so sure.

THE CASE FOR MORE RESEARCH

In 1995, as part of the FAA and NTSB’s investigation into Robinson loss of main rotor control accidents, Robinson conducted a series of flight tests with an R44 at its facilities in Torrance, California. The aircraft was instrumented to record information from the main rotor system, performance information, and flight control positions.

As was the case for similar testing performed with the R22 in 1982, the tests indicated that the aircraft could safely perform a full range of normal maneuvers — including engine power reductions and other flight training maneuvers — without any main rotor divergence tendencies.

However, the flight tests could not safely evaluate the aircraft’s response to large, abrupt cyclic inputs in normal high-speed forward flight, a condition in which the cyclic is already displaced forward and to the right. So the FAA awarded a grant to the Georgia Tech School of Aerospace Engineering to develop a high-fidelity computer simulation model to investigate the response of the R22 to selected control inputs and wind gusts.

The school used a blade element approach to develop the model through its Flight Simulation Lab. But as the NTSB explained in its 1996 special investigation report, “model-

ing of such a complex system required more resources than had been allotted for the project.” With its limited funds, the FAA elected to investigate the model’s response to only a small set of cases involving large control inputs.

The results did indeed suggest that large and abrupt control inputs could lead directly to mast bumping and loss of main rotor control. However, the NTSB noted, because typical pilot control inputs while reacting to flight dynamics were not modeled, “it is unknown if smaller control inputs would have produced mast bumping.”

The Georgia Tech report “strongly recommended” additional development of the model, finding it “clear that some additional investigations are warranted in this area.” The NTSB endorsed this conclusion in a recommendation of its own, which called for the FAA and NASA to work together to continue the development of the simulator model of lightweight helicopters.



**BRING IT... WITH
BAMBI MAX[®]
BRING IT... WITH
POWERFILL[™]**

Bring Bambi Max with Powerfill and bring more water per fuel cycle to the fire line. Efficiently manage your bucket load in the dip site and maximize your operational effectiveness and safety.



Bambi
BUCKET[®]
Driven by Innovation

International: 1.246.228.4908
Canadian Tel: 1.604.946.3131
Toll-Free: 1.866.43.BAMBI
E-mail: sales@sei-ind.com

WWW.BAMBICKET.COM

In 1998, however, the FAA determined that such a simulation tool would have “limited application,” and that “subsequent validation of the math model would involve extensive testing with significant risk to flight safety.” The NTSB accepted that the FAA had reached the limits of its technical involvement, and the effort was dropped.

Fifteen years later, New Zealand’s TAIC revisited the subject during its investigation of the Kaweka R66 crash. According to the commission, “Robinson submitted that turbulence alone cannot lead to low G mast bumping, adding that an improper input or reaction by the pilot was also required.”

That, of course, is what I had been taught as a student on the R22. But unlike me, the commission didn’t accept it as proven fact. The TAIC acknowledged that Robinson helicopters can be operated safely in some degree of turbulence, as demonstrated by their extensive operational history. However, it argued that the behavior of the Robinson rotor system in turbulence has not been fully tested, and that the low-G conditions that have been tested were planned maneuvers in which the test pilot initiated an immediate recovery, thus avoiding any subsequent dynamic response.

The commission also called attention to Robinson’s own report on its R66 rotor flapping survey, which stated, “Although low-G flight characteristics may be similar between Robinson models, the exact boundary between ‘safe recovery can be performed’ and catastrophic mast bumping cannot be predicted. Small changes in entry speed and pilot technique may produce large changes in roll rates.”

In recommending that the FAA and NASA reinstate research into two-bladed, teetering, underslung rotor systems, the TAIC pointed out that computational sciences and aerospace engineering have advanced greatly since 1995. It suggested that remotely controlled helicopters could provide data on rotor behavior under conditions that are too dangerous for test pilots, thus circumventing one of the FAA’s original concerns.

The TAIC’s recommendation sounded reasonable to me, but I’m not an expert. So I paid a visit to two people who are: Daniel Schrage, director of the Center for Aerospace Systems Engineering and the Vertical Lift Center of Excellence at Georgia Tech, and Marilyn Smith, associate director of the school’s Vertical Lift Center of Excellence.

Schrage was the lead investigator on the original research conducted for the FAA in 1995. “We had a really talented team working on it,” he recalled. “I think we did the most creditable job we could have done on it at the time.”

But he and Smith agreed that modeling techniques and computing technology are far ahead of where they were 20 years ago. “The development of aeroelastic [modeling] tools are now coming into their own,” said Smith, explaining that researchers today have the ability to model much more complex aerodynamic phenomena, including transient conditions that could lead to mast bumping, and ways in which the fuselage interacts with airflow.

Smith suggested that modeling tools already developed by the U.S. Army and Georgia Tech in its capacity as a Vertical Lift Center of Excellence could be readily applied to Robinson helicopters. And Schrage echoed the TAIC’s suggestion that an instrumented, remotely piloted aircraft could be used to validate the simulation model without putting a test pilot at risk.

“This is a civil safety problem for helicopters that really needs to be addressed,” Schrage said. “Someone needs to go back and close the loop.”

THE PILOT HANDLING PROBLEM

When I spoke with Robinson Helicopter Company president Kurt Robinson about the TAIC’s recommendations, he told me that it’s hard to argue against more research, and that he had no objections to further modeling and simulation efforts. But he emphasized

that the company has flight tested its helicopters repeatedly over the years, looking for any indications of main rotor divergence. It simply hasn’t found any within the helicopters’ normal operating envelope, which he takes as strong evidence that mast bumping really is a pilot handling problem.

Instead of searching for hypothetical unknown causes of mast bumping, he said the company is focusing its efforts on addressing known causes — namely, deliberate or inadvertent flight into low-G conditions. “Our position has always been that you avoid the feeling of weightlessness in the helicopter,” he said. (An exception to this is the “weightless” feeling upon entry into autorotation, which is not associated with mast bumping, despite a common misconception that it is.)

In its report on the Kaweka R66 crash, the TAIC found that at the time of the accident, Robinson helicopter flight manuals did not adequately warn pilots of the hazards associated with turbulence. In response, the company added a new “caution” notice to the normal procedures section of the R44 and R66 flight manuals, advising pilots to reduce power and use a slower than normal cruise speed if turbulence is expected. The company also revised its safety notice regarding flight in high winds or turbulence to emphasize that helicopters are more susceptible to turbulence at light weight, and advising pilots to “reduce speed and use caution when flying solo or lightly loaded.”

Meanwhile, New Zealand’s Civil Aviation Authority (CAA) has taken steps to strengthen its training requirements for pilots of Robinson helicopters. Although the CAA enacted some new training require-



Twenty years ago, flight data recorders were far too bulky to install on an aircraft as small as a Robinson. Today, lightweight and affordable cockpit video and flight data recorders are readily available — and could be key to finally solving the mysteries of mast bumping. **Skip Robinson Photo**

SKYe SH09



The Swiss response to making a helicopter

The SKYe SH09 offers exceptional hot and high performance and takes new paths offering the highest standard in the industry with dual hydraulic and dual electrical systems, a full glass cockpit suite, an engine inlet barrier filter, and more to come.

Join us in Amsterdam, on booth N°12B10, from October 11 to 13



Swiss movement



ments in 1995, they were never as stringent as the provisions of SFAR 73, and they were not enforced consistently. Effective July 1, 2016, the CAA has adopted more of the requirements of SFAR 73, such as the requirement that students receive 20 hours of dual flight instruction before flying solo in the R22 or R44. The CAA has also spelled out who can conduct Robinson safety awareness training, and how that training should be conducted.

Notably, the CAA has also now mandated that “low-G hazard training must not be demonstrated or practiced in flight.” Robinson submitted to the TAIC, and Kurt Robinson reiterated to me, the company’s belief that New Zealand’s high rate of mast-bumping accidents is related to the fact that instructors there have continued to demonstrate low G to their students, when such demonstrations have long been prohibited in the rest of the world. Besides the fact that some mast-bumping accidents have occurred during low-G demonstrations, Robinson has suggested that such demos could engender “a false sense of security” in the pilot because they do not accurately replicate a sudden low-G roll. As the TAIC explained, “in fact, if it happens, the roll is very rapid, leaving the pilot, no matter how experienced, virtually no time to react before a mast bump occurs.”

Because it has been impossible to safely demonstrate this kind of realistic low-G roll in flight — including during certification flight testing — it has also been impossible to say under what conditions an average pilot could be expected to recover from one. And this has led to some differing opinions on the best and most effective recovery technique.

The technique officially endorsed by Robinson is the same one that was drilled into me during my own flight training: “first aft cyclic to reload the rotor disc, and only then left cyclic to correct the roll.” However, Robinson’s own Safety Notice 11 cautions against too abrupt an application of aft cyclic during the recovery from a low-G condition, explaining that the resulting main rotor torque reaction, combined with tail rotor thrust, can also lead to a rapid right roll. The safety notice calls for “gentle aft cyclic,” but this might be hard for a pilot to gauge in an emergency, especially without previous practice.

The high-time Robinson flight instructor Simon Spencer-Bower, owner of Wanaka Helicopters in New Zealand, has recently argued for an alternative low-G recovery technique: coordinated application of down collective, aft cyclic, and right pedal (as in a quick stop maneuver) which will reduce the tail rotor thrust that is contributing to the right roll and reload the rotor disc at the same time. “I consider low-G demonstrations would increase the awareness of the dangers of low-G roll and show how important it is to reduce power, and it is sad that they are now forbidden to be demonstrated,” Spencer-Bower said. (Kurt Robinson told me that the company “has always felt lowering the collective is helpful,” but wants to emphasize aft cyclic because it directly addresses low-G loading. Note that some pilots have mistakenly interpreted “reload the rotor disc” to mean they should *raise* the collective, which will only make the situation worse.)

Further modeling of the mast bumping phenomenon could provide solid evidence for the relative merits of these various recovery techniques, leading to better and clearer guidance for all helicopter pilots. Validation of main rotor behavior outside the established flight envelope could also allow for realistic simulator training of low-G conditions. Even if one contends that low-G demonstrations in flight impart a false sense of security, I’m not sure that my own training gave me any better appreciation for the reality of a low-G roll. A visceral simulator demonstration probably would have done more for me than a dozen repeat viewings of *Mast Bumping: Causes and Prevention*.

SOLVING THE MYSTERY

For all that we might learn from further research, however, there’s one thing we’ll never know — what really happened in the cockpits

of those helicopters that broke apart in flight. When the victim of such an unexplained breakup is simply the anonymous “pilot” in an accident report, it’s easy to imagine him or her doing something reckless or unauthorized; something that “*you* as a pilot can prevent by the way *you* handle the aircraft.” When the victim is a friend, however, that assumption becomes a lot harder.

In August of this year, several months after I had started researching mast bumping, New Zealand’s TAIC released its investigation report for the February 2015 Robinson R44 in-flight breakup that killed flight instructor Stephen Combe and his student, James Patterson-Gardner. I met Combe in 2008, when I flew with him for a story about mountain flying training in New Zealand. Like his former students who were interviewed for the investigation, I had found him to be “a very thorough and professional instructor and pilot” who had “good empathy with his students.” By the time of the accident, he had accumulated around 4,500 flight hours in helicopters, including more than 2,400 hours of mountain flying and nearly 1,400 hours of flight instruction.

Investigators originally suspected that the accident might have been the result of a main rotor blade fatigue failure, and they issued an airworthiness directive that grounded R44s fitted with a certain model of rotor blades. However, the grounding was lifted after a metallurgist determined that the blade fracturing in the accident was due to impact, not fatigue. Investigators found that mast bumping initiated the in-flight break up of the helicopter, but they were unable to say what caused the mast bumping event. They did not find any mechanical defect or failure that could have contributed to the accident, and found it unlikely that the helicopter had experienced low main rotor r.p.m.

So what happened? The accident occurred when the aircraft was flying across mountainous terrain at a relatively high forward airspeed, estimated at about 102 knots. Although the weather was generally calm, investigators found it “about as likely as not” that the aircraft had hit a pocket of light to moderate turbulence, and “about as likely as not” that the student had been on the controls at the time of the event. Combe had used his mobile phone at an earlier point in the flight, so it’s possible that he was distracted, or had simply let his guard down, when his student made an abrupt or improper control input. But this is speculation. Like so many similar accidents, this one occurred for “undetermined reasons.”

“The uncertainty around the circumstances of this accident are not unique,” the TAIC stated. “There have been many other fatal mast bump accidents involving Robinson helicopters in New Zealand and around the world that have gone largely unexplained.”

Twenty years ago, the helicopter industry had to take such uncertainty as a given. Cockpit voice and flight data recorders existed, but they were strictly for transport-category aircraft, as they were far too heavy and bulky to install on a helicopter as small as a Robinson.

Today, that’s no longer the case. As the TAIC pointed out, lightweight and affordable cockpit video and flight data recorders are now readily available, and are installed as standard equipment in some smaller helicopters. Widespread adoption of these devices could finally solve the mystery of mast bumping, supplanting theories and speculation with real evidence.

“It is difficult to identify the lessons from an accident and make meaningful recommendations to prevent similar accidents if the underlying causes cannot be determined,” the TAIC concluded. “This is a serious safety issue that the industry will need to address.”



Elan Head | An FAA Gold Seal flight instructor with helicopter and instrument helicopter ratings, Elan holds commercial helicopter licenses in the U.S., Canada and Australia. She is also an award-winning journalist who has written for a diverse array of magazines and newspapers since the late-1990s. She can be reached at elan@mhmpub.com.



ONE-ON-ONE, REAL-WORLD TRAINING

PRIVATE PILOT SPECIAL OFFER
\$18,995*
SAVE OVER \$3,000



GUIMBAL CABRI G2
MOST MODERN AND SAFEST TRAINING
HELICOPTER IN THE WORLD
DON'T SETTLE FOR LESS!

40 HOURS DUAL FLIGHT
10 HOURS SOLO FLIGHT
20 HOURS GROUND
TEXTBOOKS AND MATERIALS

***FINANCING AVAILABLE**

FAA tests and related fees are not included
Course prepares you for the Private Pilot checkride, does not guarantee a pilot certificate

www.collegeaviationdegree.com
www.flyprecision.com
(503) 537-0108

FDC/Aerofilter is now Aerometals.
New Name. Same Great Products.

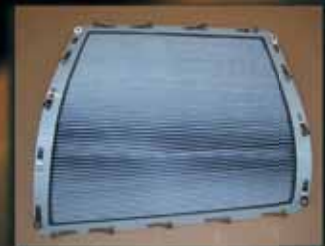

The EC-135 Inlet Barrier Filter System

- Combat Erosion
- Eliminate FOD
- Extend engine life
- Preserve power margins
- Reduce engine overhaul cost

EASA Approved!

Engine Inlet Barrier Filtration Systems **Aerometals** for Pure Air in Any Environment.

800.350.6674 or visit www.aerometals.com

The Marengo Swisshelicopter SKYe SH09, powered by a Honeywell HTS900 engine, looks set to open a new chapter in light single-engine rotary-wing flight. Certification and first deliveries are targeted for the end 2017.



Download as wallpaper at verticalmag.com/wallpaper



REACHING *for the* SKYe

In launching the SKYe SH09, Marengo Swisshelicopter is facing the dual challenges of being a startup company in an industry dominated by established players, and bringing a clean-sheet design to market. *Vertical* visited the company's headquarters in Pfäffikon, Switzerland, to find out how it's faring.

Story by Oliver Johnson | Photos by Eugen Bürgler





Marengo unveiled the first prototype during a special event at its Mollis facility in November 2013.
Marengo Swisshelicopter Photo



The SH09 took its first flight — in Mollis — on Oct. 2, 2014.
Marengo Swisshelicopter Photo



Chief flight test pilot Richard Trueman with flight test engineer Peter Wittwer.



In amongst an apple orchard, deep in the rolling hillsides of Switzerland, lies an unassuming farmhouse that contains a remarkable secret: after decades of producing apple juice and cider, it's now home to a company that's seeking to redefine the global single-engine helicopter market. That company is, of course, Marengo Swisshelicopter, and the product it's fermenting in its barnhouse in Pfäffikon — about half an hour's drive from Zurich — is the SKYe SH09.

First introduced to the industry at Heli-Expo 2011 in Orlando, Florida, the SH09 has an eye-catching clean-sheet design, including a full carbon-composite airframe, a shrouded tail rotor, a large fuel tank for extended range, and an attention-grabbing "high-visibility" cockpit.

But while the SH09 has become an increasingly familiar presence within the industry, the company behind it remains something of a mystery to many. *Vertical* travelled to the manufacturer's facilities in Switzerland to discover the company behind the

product — and get an update on one of the most exciting developments in the industry.

The story of Marengo Swisshelicopter is entwined with the story of Martin Stucki — the company's engaging founder and CEO (the name Marengo comes from *Martin Engineering and Consulting*). A mechanical engineer by trade, and a pilot through passion, he worked for a few different companies in Switzerland before founding an engineering company — Marengo — in 1997. (This company still exists today as a separate entity to Marengo Swisshelicopter, and provides its expertise to its sister company on an ad-hoc basis.)

But while engineering was his day job — and one in which he was clearly gifted — the world of rotary-wing flight had never been far from his thoughts. He sketched his first helicopter designs while still in school, and took his first one-hour helicopter training flight (a gift from his mother) before he began his engineering degree. As his career progressed, his spare time



The second prototype of the SH09 flies over the airstrip in Mollis, Switzerland. The two main design changes between the first and second prototype were in the rotorhead and control cables — with the latter changing from flex cables to push/pull rods.

Flight test pilot Dwayne Williams (left) with Marengo CEO and founder Martin Stucki (right) shortly after the aircraft completed its first flight.



was spent earning his private and commercial pilot licenses, and then flying freelance for local helicopter companies. But while he enjoyed his time in the cockpit, he became frustrated with elements of the design of much of the light single fleet — a fleet that hadn't seen a clean-sheet entrant for decades.

"If you fly helicopters, you see a lot of sometimes small things where you think you can do better," he told *Vertical*. And so, in 2002, he began creating the aircraft he would like to fly on computer-aided design (CAD) software. Market research into the various market segments revealed a viable market in the 2.5-tonne class, and Stucki formed Marengo Swisshelicopter in 2007 as the project became more serious — and the search for funding to enable the aircraft's development began in earnest. Stucki admits this was no small task, but he eventually found a group of investors who saw the potential in his design, and the development of the SKYe SH09 officially began in 2009 (enshrined in the "09" of "SH09").

At this time, there were just seven people working on the project. This had grown to just 15 by 2011, but 2013 marked a period of four years of intensive growth. Today, the company employs about 120 people, and it expects that figure to grow to 150 by the end of the year.

From the beginning, the company's investors provided the funds to attract the best and brightest to the project — including Mathias Senes, the company's chief commercial officer, who joined following a decade at Eurocopter (now known as Airbus Helicopters) where he had sold helicopters in more than 45 countries and introduced seven new aircraft types to the market.

"We have a great team of shareholders who have given us the opportunity to hire experts in each domain and I think this enables us to build a sound infrastructure in parallel to a fantastic product," said Senes. "It's a market with very high barriers, and you don't just come into a client's door and bring in a new product like that and claim superiority and walk away. You have to have a bit of a relationship, and [have had] credible success in the past."

As the company has grown, it has welcomed a mix of youth and experience into its ranks to provide the benefits of both.

"For some parts of the project it's important for us to have people who have not had years of thinking along the same tracks, so you really can generate innovation," said Stucki.

ON THE APPLE FARM

Marengo's operations in Switzerland are split between the small towns of Pfäffikon and Mollis. The former is the site of the company's headquarters and engineering facility, while the latter, located about an hour's drive southeast of Zurich, hosts its flight test operations — and its fledgling assembly plant.

The majority of the company's employees — about 90 to 100 — work in the sprawling converted farmhouse and adjoining barns that form Marengo's headquarters in Pfäffikon. It's certainly a very picturesque location, perched on the top of a fairly precipitous hillside overlooking the sleepy rural town. And, given that the building's conversion has left the exterior relatively untouched — with the wooden façade remaining in places — it's still something of a surprise to pass through the front door and find a bustling open-plan office. The farmhouse has been in Stucki's family for four generations, and remains his home — and not just spiritually. His family name is on a plaque hanging from an otherwise nondescript door on the ground floor of the office building — and the only real indications that it's not his office, but his house, are the proudly displayed drawings from his young daughter pinned alongside it.

“For me, it’s OK; it’s fine,” he said of living within his office. “I can also switch [the working mentality] on and off at home. It’s also an advantage — I can hop into my apartment and have lunch with my family, so there’s not just disadvantages.”

New sections of the barns adjoining the farmhouse are converted to accommodate the company’s growth as needed.

Within the office, the company uses Advanced Rotorcraft Technology’s Flightlab simulation software to study the stress loads and effects during testing, and for those working on the aircraft’s component design, the facility contains a laser printer and a five-axis CNC machine. These allow engineers to immediately prototype parts if timing is likely to be an issue with a supplier.

“In the end, we want to be an assembler — like Boeing and Airbus — so it gives us the flexibility to change the supplier if the quality is not good, improve the component, or even plan in the future local assembly lines,” said Senes. “[But] until a supplier is selected, we still have our own capacity of production, which gives us a bit more autonomy, and are able to — especially with the testing — proceed without delays.”

The original Marengo — Stucki’s engineering company — also works from the same building, and can be brought in to work on parts when needed.

At the beginning of the program, Marengo utilized a wind tunnel in South Africa to confirm the design of the aircraft. Today, the aircraft’s dynamic components are evaluated using equip-

ment including the company’s own whirl tower to test the rotor-head, blades and tail boom; a Stucki-designed gearbox testing machine; a rotor blade test bench; and a hydraulic test bench.

The Mollis facility is largely run from a rented hangar space alongside an airfield, but at the time of *Vertical’s* visit, Marengo had just broken ground on the assembly plant that is to be created in a series of modules alongside its current location.

The final part of the Marengo Swisshelicopter organization is in Germany, where the company’s office of airworthiness is located. This facility, established in 2012, contains 15 compliance verification engineers who work to ensure a smooth certification process with the European Aviation Safety Agency (EASA).

A CLEAN-SHEET DESIGN

Stucki explains his design philosophy for the SH09 as creating “a helicopter from pilots for pilots.” The result of this is an aircraft with attributes such as a large cabin, a flat floor, a high ceiling, large clamshell rear doors, pilot seats that are adjustable in height and length — and, of course, that high-visibility cockpit. Clearly, ergonomics and comfort are central to his thinking. “We’re looking at what is the operator’s need and how can we can fulfill it,” he said. With this in mind, the aircraft has been designed to fly as impressively as it looks, with excellent hot and high performance (provided by its 1,020-shaft-horsepower Honeywell HTS900 engine), long endurance, smooth flight, and a low noise signature.

The SH09 lands after completing another set of flight trials at Marengo’s base in Mollis. Next door to the rented hangar space seen on the left of the image, the company is building its assembly plant for the aircraft.





Mission Optimized

From ferrying offshore workers to transporting medical specialists, your fleet is expected to deliver a smooth ride—but without compromising safety. Honeywell's Sky Connect Tracker III and Health and Usage Monitoring System (HUMS) work in tandem to integrate flight operations and maintenance activity. Sky Connect Tracker III provides voice, text, data recording and mapping capabilities, while HUMS measures the performance of mission-critical components.

Connect with us and find out how Honeywell ensures excellence in flight and on the ground.

Honeywell

© 2016 Honeywell International. All rights reserved.

For more information, please visit
aerospace.Honeywell.com



There's a strong customer focus at Marenco on the operator. We want to understand what they do, how they do it, and where there are opportunities to improve on their current platforms.

— **Richard Trueman, chief flight test pilot, Marenco Swisshelicopter**







Marengo flight test pilot Richard Trueman said the high visibility cockpit — as displayed here through an artist's rendering — would be the main "wow" factor when pilots climb into the aircraft. **Marengo Swisshelicopter Image**

At present, Marengo is looking to certify the aircraft at an empty weight of 1,300 kilograms (2,865 pounds), with a maximum take-off weight (with an external load) of 2,800 kg (6,170 lb.). Perhaps the most eye-catching performance metric is its sling-load capacity of 1,500 kg (3,300 lb.), which is maintained while in hover in ground effect up to 3,000 meters (ISA plus 20 C).

Senes said the aim is for the SH09 to be a "vertical takeoff platform" for operators.

"For our operators to make money with a single engine, they have to be able to benefit from a platform concept, where they can go from three-seater to a shuttle eight-seater, back to a rescue kind of platform, and back to maybe an electronic newsgathering aircraft," he said. "This is really the essence of making the aircraft profitable for our clients."

And while Marengo doesn't anticipate a substantial market for the SH09 among air medical operators in Europe (given their preference for twin-engine aircraft for the role), Senes said the emergency medical services market in North America "is going to be very important" for the company — with the SH09's clamshell rear doors, shrouded tail rotor, and high tail boom all appealing aspects for patient loading and unloading.

Key to providing both the performance and size required to make the SH09 the multimission platform Marengo hopes it will become is the aircraft's fully carbon composite airframe. "There's no other material today that brings the benefits of

rigidity, strength, and light weight," said Senes. "It made it possible to come with a multipurpose platform that can really go from VIP to passenger transport and have superior performance to the competition. Without carbon we couldn't do it. It was too heavy to reach the volume that you see in the cabin."

Aiding that vision of volume is the fact that the aircraft's crashworthy Kevlar-threaded fuel tanks have been built into the walls and floor of the cargo hold, opening up space underneath the crashworthy individual rear seats. This allows them to be fully adjustable — even in height — and still leaves a sizeable cargo hold that Marengo claims will fit up to 10 pieces of luggage with four passengers on board. Despite remaining hidden, the fuel tanks are ample, providing 750 liters of fuel, which could provide close to five hours' endurance.

The aircraft will be offered in different layout configurations, with the baseline version including four passenger seats plus two pilot seats. The high-density configuration sees five seats in the rear, as well as two passenger seats alongside the pilot — but this configuration requires covering the floor window. Interestingly, Senes said the aerial tourism operators he has spoken with said they'd rather forego the extra seat in order to keep the floor window.

Several aspects of the SH09's design are aimed at reducing its noise signature, including the swept back tip on the aircraft's five main rotor blades (which also provides extra lift), a relatively

Focus



Lives are on the line

When a rescue hoist is all that stands between life and death, you need to know it will work. Breeze-Eastern equipment is designed and hand crafted by the world's most experienced and knowledgeable helicopter rescue hoist experts.

Breeze-Eastern is the world's only dedicated helicopter hoist and winch provider.



breeze-eastern.com

Access to the SH09's cabin is made easier with large rear clamshell doors and a high tail boom — particularly appealing qualities for medical transport applications.



The full-scale mock-up of the SH09 that Marengo Swisshelicopter brought to Heli-Expo 2015 in Orlando, Florida, drew crowds to the manufacturer's booth. The aircraft is now a familiar sight on the trade show circuit.

Skip Robinson Photo



Marengo's Mathias Senes said said helicopter production was a perfect fit for the Swiss talent for producing high value hand-assembled products, for niche markets, at low volume.



With the first set of test flights complete, the program was set to begin the second stage in September. This will take the aircraft into extended pattern flying.



narrow tail boom, and the "Maestro" — Marengo's shrouded tail rotor. Compared to other enclosed tail rotors, it has a relatively wide diameter and a thinner chord — with the aim being to increase its visibility to the airflow, and thereby give the aircraft greater tail rotor authority.

The Honeywell engine will be provided with no time between overhaul (TBO) limits, in keeping with the condition-based maintenance policy that will be applied to the entire aircraft (the SH09 will be delivered with a health and usage monitoring system). "The TBO has a strong impact on the cost of operation because it creates a cost of maintenance at a fixed time, and creates downtime for the aircraft," said Senes. "Having this no TBO policy, it's basically continuous maintenance — no peak moment. It flattens the cost line and it flattens the downtime."

Stucki said this has been a major consideration as the aircraft's design has evolved, as ease of access for technicians must be optimized. "It's really daily work to get it to the point where maintenance is easy," he said, "so you can get to the parts without having to remove five other parts to repair something."

The prospective lower maintenance cost is one of the aspects Marengo is hoping will offset any sticker shock at the SH09's \$3.5 million price tag — substantially higher than the Airbus Helicopters AS350 AStar, which is the major presence in the

General Data

Take off Power	820 shp	603 kW
Continuous Power	757 shp	557 kW
Approx. Max. Weight	6160 lbs	2800 kg
Approx. Empty Weight	2860 lbs	1300 kg
Approx. Useful Weight	3300 lbs	1500 kg
Useable Fuel Capacity	211 gal.	800 L
Approx. Range	280 nm	500 km
Length Overall	42.55 ft	12.97 m
Width Overall	38.1 ft	w 11.0 m
Power Plant	1 Honeywell HT5 900-2	
Approx. Endurance	3.8h (800I/80% CP)	
Capacity	1 Pilot + 6/7 passengers	

single-engine utility market. However, this price still makes it competitive with other six- to eight-seater single-engine aircraft such as the Bell 407, Leonardo AW119, and Airbus Helicopters H130.

TESTING TIME

Vertical arrived at Marenco's flight testing facility in Mollis, Switzerland, as the program was finishing its first block of tests. Located in the base of the Linth valley, surrounded by mountains, it's a spectacular backdrop to watch a brand new aircraft being put to the test. The day before, it had notched a considerable milestone — a new fastest flight speed of 120 knots — and morale was high among the testing team.

The team includes chief flight test pilot Richard Trueman, flight test pilot Dwayne Williams, chief flight test engineer Dominic Cheater, and flight test engineer Peter Wittwer. Williams performed most of the flying on prototype 1 (P1), which completed its first flight on Oct. 2, 2014, and Trueman has done the majority of the testing on prototype 2 (P2), which began flying on Feb. 26, 2016.

"It's an absolute delight to fly," Trueman told *Vertical*. "It's a big single-engine helicopter — the size of a [H]135. The cockpit environment is very light and airy, with lots of transparencies, and a very good field of view. It's got very simple controls — it's very quick to start. Yesterday, from hitting start to being ready for takeoff, was two minutes — and this was a flight test aircraft."

Trueman said pilots will likely find the SH09's field of view and simplicity of operation its most appealing aspects. "The number one 'wow' factor when people sit in the aircraft is just looking at the view," he said. "And it's doesn't just look nice, it makes your job as a pilot easier if you're trying to get close to something on sloping ground, [or] you're doing long-line work, [or have] passengers doing a tour over the Grand Canyon, who all want to look out."

The aircraft's development has been embedded within EASA's certification process. Trueman said its flight envelope has been gradually opened up, with the aircraft having flown at 97 percent of its maximum internal load takeoff weight, up to 3,000 feet pressure altitude, and performed "very limited" autorotations.

The flight test campaign has been divided into three phases, with first — involving work over the airfield — completed at the end of August. The second is due to start in September, and will involve extended pattern flying. "We're going to go for probably within plus or minus five miles of the field," said Trueman. "We'll shoot for about 7,000 feet, and speed-wise I hope to push it up to Vne, which we've got at 151 knots."

Overall, there will be three aircraft used in the flight testing program, with P2 and P3 (the latter is currently in production

in Mollis) working as the main vehicles for certification testing. According to Stucki, the two main design changes between P1 and P2 were in the rotorhead and control cables — with the latter changing from flex cables to push/pull rods.

P3 is due to fly before the end of this year, and Stucki said there wouldn't be any major changes from P2. "We optimized the fuselage, [so] it's now closer to serial production," said Stucki. "We optimized weight, [and] we optimized manufacturing — there is no conceptual change or something like that. It's really to have all the details changed and have it ready to go to the certification flight tests."

HEADING TO PRODUCTION

The construction of the SH09 assembly plant in Mollis will be completed in modules, and will be ongoing until the end of 2017,

Visit us at Helitech, Stand 12F70



Air Apparent.

Changing the airflow around your H125 tailboom will change the way you fly.

BLR's patented **FastFin**® technology will be available for both new H125s and as an aftermarket modification.



www.BLRaerospace.com/4811 | 425.405.4811

when the aircraft is slated for certification and first deliveries. Production numbers will be progressively ramped up from an anticipated 10 to 15 units in the first year, to eventually 100 units annually.

Senes said Marengo is aiming to have optional equipment certified in parallel to the aircraft.

Marengo has received about 90 letters of intent for the SH09, and it is now focusing on firming these up into full contracts. "We have letters of intent that are not firming up, but the operators in question are so strong that if we do what we say, there's little chance that they will turn their back to us," said Senes.

The company is also looking to build up its launch customer base, which currently includes Swiss company Air Zermatt and Canadian operator Horizon Helicopters. "We are looking for people who fly as much as possible so that we get the feedback

from these flights — and the guarantee that this team will feed back to us all the information that they build up, if not on a daily basis, every two or three days," said Senes.

Air Zermatt is a regular visitor to the flight test facility in Mollis to discuss optional equipment or provide feedback on the man-machine interface.

"There's a strong customer focus at Marengo on the operator," said Trueman. "We want to understand what they do, how they do it, and where there are opportunities to improve on their current platforms."

The company is initially focusing on the North American and European markets, with Federal Aviation Administration certification set to follow EASA certification. That focus will likely see an assembly line established in the States.

"I think we will for sure do additional assembly lines," said Stucki. "North America, that's a more or less given, [with] 45 percent of the market, we will go for this and establish something there."

Beyond this, the company has appointed distributors in Australia, Japan, and Guatemala to help develop the global market for the SH09. "We looked at what the competition has done," said Senes. "We saw that the work with partners is a good way to grow a network, and you gain the local knowledge."

Looking even further ahead, Stucki said a twin variant would be a logical next step, with "some genes of a twin" already having been incorporated into the SH09's basic design.

Entering such a closed market has certainly presented its challenges, and Marengo faced a fair amount of cynicism as it sought to establish itself — and its product — within the global helicopter industry. "People said this will never happen, you will never fly, you will never get the gearbox, you will never get the rotor blades and rotorhead — it's impossible," said Stucki. "And especially in Switzerland there is nothing like the culture to develop new industrial project. Now we fly, so these voices are going down a little bit. Sometimes they are still there, but this is something you have to live with."

For now, Stucki is pleased with how far the project has come, with the long journey from schoolboy's sketchbook to certified aircraft almost complete. "We're showing you can get to an end with such a project," he said. "I'm achieving my professional dream — and for sure it's really exciting!"

**THE NEXT GENERATION OF AVIATION
NVG MOUNT AND BATTERY**

AERONOX®

ASU Inc.

ASU safeguards those who defend and protect with an entirely new NVG mount and battery pack. Built from the ground up with pilot input, it's lightweight, low-profile, reinforced, and modular; extending the overall product life. The updated features increase adjustment, durability, and ease of operation.

PRE-ORDER NOW!

MANUFACTURED BY:
WILCOX®

www.asu-nvg.com
+1 208.426.8117

Oliver Johnson | Managing editor of Vertical and Vertical 911 Magazines, Oliver can be reached at oliver@mhmpub.com.
Follow him on Twitter @orjohnson_



A Difference You Can Clearly See.

High-quality replacement windows for your helicopter.

Get the superior optics, exceptional fit and long-lasting durability you need with Tech-Tool Plastics. Since helicopter windows are our only business, we deliver unmatched service and expertise.

Discover the Tech-Tool difference for yourself.

info@tech-tool.com
1.800.433.2210 | www.tech-tool.com

Airbus Helicopters, Bell Helicopter,
MD Helicopters, Schweizer, Robinson



TECH-TOOL PLASTICS

EXCELLENCE. ELEVATED.

Visit us at Helitech, Stand 12B41



Versatile *by* DESIGN

As the Sikorsky S-92 celebrates one million flight hours, we take a look at the mark the heavy-lift juggernaut has made on the global helicopter industry.

By Kenneth I. Swartz

The Sikorsky S-92 flies to places most people have never been. From Barrow, Alaska, in the Arctic; to Mecca, Saudi Arabia, in the Middle East; and to the Falkland Islands in the South Atlantic, the S-92 has proved itself across an extraordinary range of challenging missions and operating environments since it entered service in late 2004.

Designed by Sikorsky engineers to be a high-speed, long-range, heavy-lift, all-weather helicopter with a large stand-up passenger cabin, the S-92 also utilized the latest technology to achieve low direct operating costs and meet new certification standards for high reliability and safety.

Versatile by design, the S-92 has become a workhorse in the offshore oil fleet, performed more than 91,000 search-and-rescue (SAR) missions, operated security missions in hot and high places, and its military variant — the CH-148 Cyclone — recently began testing aboard Canadian naval frigates in the North Atlantic. Eleven governments also use a fleet of S-92s to fly their heads of state in secure comfort, and the United States will join this exclusive list in 2020, when new U.S. Marine Corps VH-92s start serving the White House as the new presidential helicopter fleet.

In May 2016, Sikorsky and its customers celebrated the S-92's milestone one millionth flight hour. The landmark was achieved by a worldwide fleet of 275 aircraft, just 12 years after the first production delivery, and while recording a best in class safety record and availability rate. Sikorsky is celebrating the landmark with a



Download as wallpaper at verticalmag.com/wallpaper



The North Slope Borough (NSB), Alaska, purchased an S-92 to provide a SAR/EMS response to emergencies in the northernmost region in the U.S. Based above the Arctic Circle in Barrow, the S-92 will serve a 94,796-square-mile territory and operate under harsh cold weather conditions with temperatures as low as -55 C (-67 F) with the wind chill. **Skip Robinson Photo**



Bristow Group operated 76 S-92s in early summer — the world's largest fleet — with the majority based in the U.K. and Norway. **Bristow Photo**

Babcock MCS flies over 200,000 people a year in support of the U.K.'s offshore oil and gas sector with a variety of helicopters, including the S-92. **Babcock Photo**



PHI. Inc.'s first S-92s supported BP's Thunder Horse PDQ — the largest semi-submersible production oil platform in the world — in the Gulf of Mexico. **Ted Carlson Photo**

CHC partner BHS – Brazilian Helicopter Service Táxi Aéreo Ltda flies past the Christ the Redeemer statue in Rio de Janeiro. **Riccardo Zenner Photo**





The South Korean Air Force operates three S-92s in a variety of roles, including VIP transportation.
YoHan Han Photo



Lider Táxi Aéreo S/A (partially owned by Bristow) flies 12 S-92s offshore for Petrobras in Brazil.

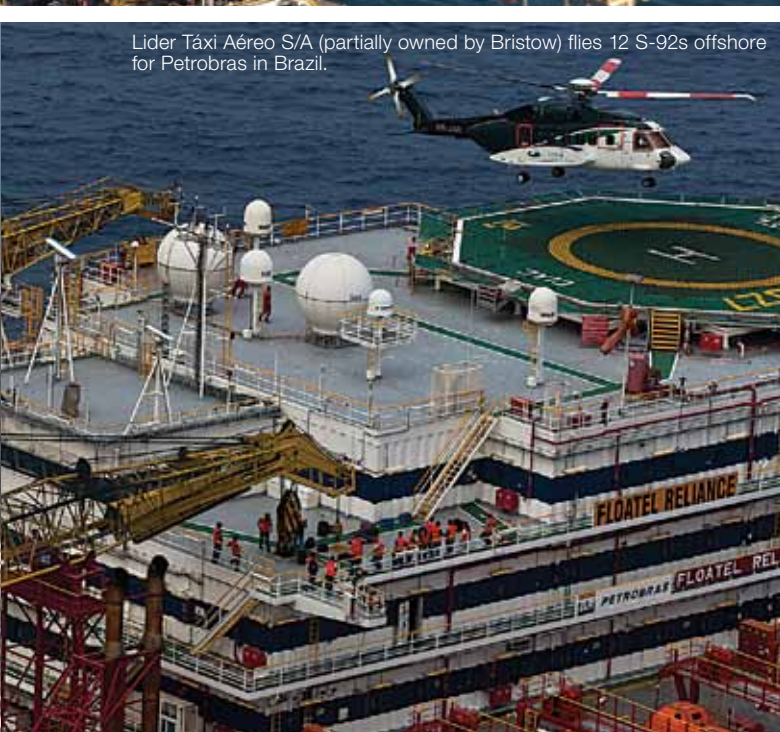

“Thanks a Million” campaign throughout 2016, recognizing S-92 helicopter customers, operators, employees and suppliers.

The milestone was reached during an extraordinary period when offshore S-92 demand and utilization had increased to fill the void created when the Airbus EC225/H225 fleet was grounded after a fatal H225 accident in Turøy, Norway, on April 29, 2016. Accidents are never welcome in the helicopter community, but helicopter operators have always been very nimble when it comes to providing service to their clients when one helicopter model or another has suffered a loss.

“S-92 fleet hours are up 20 percent this year, and we are prepared to assist our customers in any way they need to remain operational,” Dana Fiatarone, vice president of Sikorsky commercial systems and services, told *Vertical* in mid-August. “We are implementing an additional number of support measures, and are working to keep the S-92 fleet availability at greater than 95 percent.”

Fiatarone said Sikorsky is also helping customers to put idle and under-utilized S-92s back to work, as well as supporting operators who are looking to modify or convert S-92s for new crew change or SAR roles.

The S-92 fleet in the North Sea region has grown by at least 10 aircraft since April, including the addition of two new S-92s direct from Sikorsky and the arrival of S-92s previously working in Canada, Brazil, the Falkland Islands, Nigeria and the United States.

BY THE NUMBERS

Each year at Helicopter Association International’s (HAI) Heli-Expo, the helicopter industry pays a visit to the Sikorsky booth to kick the tires of a new S-92. The aircraft always looks very attractive under spotlights on the carpeted convention floor a world away from where most S-92s earn their living. Perhaps unsurprisingly, the vast majority of them are working in the offshore oil-and-gas fleet. Of the S-92’s million flight hours, about 87 percent (more than 875,000 hours) were in service of the oil-and-gas industry. The remainder was split between SAR (6.1 percent), utility/parapublic/airline (3.8 percent) and VVIP/VIP (3.1 percent).

Of the 276 S-92s delivered by Sikorsky, aircraft are currently in service with operators in nine regions: North Sea (95 aircraft), Gulf of Mexico (36), Asia (34), Middle East (26), South America (24), Canada (16), Australia (11), U.S. (six), and Equatorial Africa (six). A portion of the offshore fleet is always deployed outside its home market on international contracts.

When it comes to aircraft utilization, during the first seven months of 2016, North Sea operators flew 42 percent of the S-92’s worldwide flight hours (with 33 percent of the fleet), followed by operators in the Gulf of Mexico (21 percent), South America (16 percent), Asia (six percent) and Canada (six percent).

Interestingly, Sikorsky reports that the average number of flight hours recorded by an offshore S-92 has grown over the past four years, from 825 flight hours to 1,072 flight hours annually. This probably reflects efforts by oil companies to achieve greater efficiencies. The world’s highest-time S-92 is in Norway, and has flown 18,000 hours in about 11 years.

Sikorsky doesn’t disclose its order and delivery numbers, but the General Aviation Manufacturers Association reports that Sikorsky delivered 37 S-92s in 2013, 42 in 2014, 16 in 2015 and just four S-92s in the first half of 2016.

SIKORSKY COMMERCIAL HELICOPTERS

Sikorsky entered the commercial business 70 years ago, when it delivered three S-51s to Helicopter Air Transport (HAT) in Camden, New Jersey, in August 1946. For the next 30 years, every com-



The S-92 has been assembled in Coatesville, Pennsylvania, since the winter of 2009/10. More than 600 people work at the facility. **Skip Robinson Photo**

mercial helicopter Sikorsky delivered was a derivative of a military helicopter program sponsored by the U.S. Department of Defense (DoD). In the mid-1970s, Sikorsky self financed the development of the twin-engine S-76 as its first “pure” civilian helicopter program. The fast and sleek S-76 was certified by the Federal Aviation Administration (FAA) in 1978 and became very popular for offshore and executive transport as well as emergency medical services (EMS), SAR, and scheduled airline operations.

The S-92 made its public debut — in the form of a full-scale mockup — at the HAI Convention in Las Vegas, Nevada, where it tested the market for an S-61 replacement and larger S-76 stable mate.

The original product development strategy called for combining the General Electric CT7 engines and the dynamics technology of the military S-70/H-60 Black Hawk/Seahawk with a new rotor system and larger volume cabin. However, as the S-92’s maximum gross weight increased to 25,200 pounds (above the H-60’s component limits of 22,000 pounds) to meet customer requirements, Sikorsky had to develop an entirely new dynamics system that was 20 percent more powerful to handle the higher weights and meet new stringent Federal Aviation Regulation part 29 certification and single engine Category A performance requirements.

The three-page S-92 requirements document specified: 19 passengers; stand-up headroom; 400 nautical mile range (740 kilometers) under North Sea instrument flight rules; direct maintenance costs of \$850 per hour (in 1999 dollars); and new safety standards with flaw tolerance and basic structural redundancy.

Sikorsky identified five prime markets for the S-92: offshore; utility operations and helicopter airlines; U.S. military; heads of state and VIPs; and foreign militaries, but it took several years for the market to mature. With no U.S. military program on the horizon to help fund development, the company proceeded cautiously as it looked internationally for risk-sharing partners and military customers. Ultimately, Sikorsky formed a team with five international aerospace companies to take the project forward, and announced full-scale development of the S-92 at the 1995 Paris Airshow.

Prototype production began at the company’s facility in Stratford, Connecticut, and the sales campaign kicked off at Heli-Expo 1998. Sikorsky offered the S-92 in two configurations: a 19-seat civil transport with an airline interior and a 22-passenger military transport with side-facing seats. The offshore model was originally priced at \$12.5 to \$13 million.

S-92

by the Numbers



JUNE 1995

06.95

Sikorsky introduced the **S-92** during the Paris Air Show

AUGUST 1998

The ground test vehicle, **Aircraft No. 1**, made its first run



First Delivery:
September 2004

Global fleet distribution:

275+

Number of **Operators**

37



Flight Hours by Sector

OFFSHORE 87%
SEARCH & RESCUE 6.1%
UTILITY; AIRLINE, EXECUTIVE, VIP 3.8%
HEAD OF STATE 3.1%

Era[★]



Partnered Solutions



Let our experience guide you to a partnered solution from a diverse fleet featuring some of the most advanced helicopters in the industry. Era provides helicopters and related services to third-party helicopter operators and customers in the United States, Brazil, Colombia, Dominican Republic, India, Norway, Spain and the United Kingdom.

www.erahelicopters.com

Operating or Leasing solutions can be custom tailored for any mission anywhere in the world to include:

- Tip-to-tail maintenance support
- Inventory and tooling support
- Pilot and AMT training
- Technical and reliability support
- Flight crews
- Flexible financing options

Safe, Efficient, Reliable

An S-92, operated by Cougar Helicopters for search-and-rescue missions off the coast of St. John's, Newfoundland and Labrador, holds a hover while a rescue technician is lowered. **Mike Reyno Photo**





An overhead view of Sikorsky's Coatesville facility. The plant assembles and completes both the S-76D and the S-92. **Skip Robinson Photo**

Sikorsky displayed a special VIP version of the S-92 at HAI Heli-Expo 2013, featuring a livery that celebrated the company's 90th anniversary. **Ken Swartz Photo**



DEVELOPMENT AND CERTIFICATION

Sikorsky built five S-92 prototypes (including a ground test vehicle) in Stratford and transferred them to its flight test center at William P. Gwinn Airport in West Palm Beach country, Florida. The S-92 ground test vehicle ran on Aug. 14, 1998, and the prototype S-92 first flew on Dec. 23 that year.

During the three-year flight test and certification program, the S-92's design was refined. The engines were upgraded to General Electric CT7-8A turboshafts, the avionics system changed to the Rockwell Collins Pro Line 21 with four LCD displays, and the airframe modified with a 16-inch fuselage plug aft of the cockpit. The length of the tail rotor pylon was also reduced by 41 inches and the horizontal stabilizer repositioned to the right side to improve flight handling, permit a 50-inch wide SAR door, and improve the tail fold configuration for shipboard operations.

The development team peaked at 350 people during the flight test and certification phase, and, after 1,570 test flight hours, the FAA certified the Sikorsky S-92 on Dec. 17, 2002 — the 99th anniversary of the Wright brothers' first powered heavier-than-air aircraft flight.

The S-92 won the 2002 Robert J. Collier Trophy, and was lauded as “the greatest achievement in aeronautics or astronautics in America” by the National Aeronautic Association for its “multiple improvements in safety, operating cost, and traveling comfort.”

It was the first helicopter certified to the latest North American and European airworthiness part 29 harmonized certification requirements (through amendment 47), providing unprecedented features such as a fully flaw-tolerant design for the rotor and fuselage structures, and redundant flight-critical systems that prevent single-point failures.

“We are particularly proud of the aircraft's flaw tolerant design,”

said Fiatarone. “It leads the way by being the first aircraft certified to this rigorous standard and by meeting or exceeding oil-and-gas industry requirements.”

MISSION CAPABLE

Built for the 21st century, the S-92 (at launch) offered a potential maximum range of 480 nautical miles with 19 passengers at maximum gross weight (26,500 pounds) with 30 minutes' fuel reserve.

Powered by its two CT7-8A engines, rated at 2,520 shaft-horsepower for takeoff and 2,043 shaft-horsepower continuous, the S-92 has a never exceed speed of 165 knots (306 km/h), a maximum continuous speed of 151 knots (280 km/h), and a long range cruise speed of 136 knots (252 km/r).

The S-92 also introduced a spacious standup cabin that was higher (six feet), wider (6.68 feet) and longer (20 feet) than the S-70/H-60, and had a rear ramp/baggage compartment. A Sikorsky-developed active vibration control system provided a 30-percent decrease in vibration levels and reduced noise.

Standard safety features included high-intensity radiated field protection (HIRF), crashworthy seats for all occupants, a fuel sponson designed to keep fuel away from passengers, energy absorbing landing gear, bird-strike protection at maximum aircraft speed, and lightning strike protection.

The standard avionics suite included an enhanced ground proximity warning system, traffic collision avoidance system, and a health and usage management system.

Cougar Helicopters became the S-92's launch customer when it signed a letter of intent (LOI) on Jan. 25, 2000, for use off the east coast of Canada. In March 2003, final assembly of the first production S-92s began at the original Sikorsky factory site in Bridgeport,



Saudi Arabia's Ministry of the Interior was the first multi-role utility S-92 customer. **Ahmed Al Hader Photo**



LEVEL D HELICOPTER TRAINING FOR SUPERIOR QUALITY, EFFECTIVENESS AND VALUE

FlightSafety, the global leader in training, offers Level D qualified simulators for twin- and single-engine helicopters. Designed to enhance the safety and proficiency of helicopter flight crews, our training recognizes that different missions require different skills. Our simulator-based training provides in-depth instruction, from basic operation to highly specialized maneuvers and recovery techniques that would be difficult to perform in a helicopter. FlightSafety's extensive and growing range of helicopter training programs includes advanced-technology simulators that replicate an aircraft's exact flight and performance characteristics.

Our VITAL 1100 visual system offers resolutions of more than 12 million pixels that, combined with our exclusive CrewView glass mirror displays, delivers unprecedented fidelity. And our knowledgeable, experienced instructors are simply the best in the business, dedicated to providing the highest quality professional aviation training. That's why the majority of today's aircraft manufacturers – including AgustaWestland, Airbus Helicopters, Bell Helicopter and Sikorsky – trust us to provide world-class training. Train with us and we'll earn your trust, too.

EXTENSIVE AND GROWING RANGE OF PROGRAMS

DALLAS

Airbus H135
Bell 212
Bell 412EP
Bell 412EP-Fast Fin
Bell 430
Sikorsky S-76B

LAFAYETTE

AgustaWestland AW139
Bell 206
Bell 407
Sikorsky S-76C+/C++
Sikorsky S-92

LONDON FARNBOROUGH

Sikorsky S-92

SHREVEPORT

Airbus AS350 B2
Airbus H135

SINGAPORE

Sikorsky S-76C+/C++

STAVANGER, NORWAY

Sikorsky S-92

WEST PALM BEACH

Sikorsky S-70 A/L
Sikorsky S-70i
Sikorsky S-76C+/C++
Sikorsky S-76D
Sikorsky S-92

UPCOMING AND PLANNED

DENVER

Airbus AS350 B3
Airbus H130
Airbus H135
Bell 407GXP

SHREVEPORT

Airbus EC145



Aviation professionals from around the world trust us to provide the highest quality training and outstanding service. More than 1,800 highly experienced professional instructors deliver aircraft- and mission-specific courses, using our comprehensive training systems and advanced-technology flight simulators designed to enhance safety. Trust your training to FlightSafety. You'll see why so many aviation professionals make the same choice. And have since 1951.

For more information, please contact Steve Gross, Senior Vice President, Commercial
314.785.7815 • sales@flightsafety.com • flightsafety.com • A Berkshire Hathaway company

FlightSafety
international

Connecticut, with LOIs for nine helicopters, including two options.

The order book began to fill as the outlook in the oil and gas industry improved, stimulating new exploration activity further offshore. Along with this, new international oil companies were willing to pay higher contract rates for new generation helicopters that offered greater payload, efficiency and speed — and that were certified to the latest airworthiness standards.

The first production S-92 departed Stratford in late September 2004 on its delivery flight to PHI, Inc. in Louisiana. In the first year of service, four leading offshore helicopter operators — PHI Inc., Norsk Helikopter, CHC Helicopter Corporation and Cougar Helicopters Inc. — introduced the S-92 on offshore routes in the Gulf of Mexico, Norway and Atlantic Canada. The S-92 proved to be extremely reliable, quickly reaching aircraft utilization rates of between 90 and 160 hours a month, with Norsk (later Bristow Norway AS) leading the fleet by flying about 2,000 flight hours per year per aircraft.

In other markets, Sikorsky delivered the first corporate S-92 to the New York area in 2004, the first S-92 for a head of state to Turkey in 2005, the first dedicated SAR aircraft to CHC in 2007, and the first multi-role utility S-92 to Saudi Arabia's Ministry of Interior (MOI) in 2008. Canada became the first customer for a naval military variant of the S-92 when it signed an order for 28 CH-148 Cyclones in November 2004.

MOVING TO COATESVILLE

At first glance, Coatesville, Pennsylvania, seems to be an unlikely place for Sikorsky to assemble and complete new S-76D and S-92 helicopters, but aviation companies in the Philadelphia area have been building autogyros and later helicopters since 1929.

The transfer of the S-92 final assembly line from Stratford to

Coatesville was completed during the winter of 2009-2010, following a period when every S-92 flew from Stratford to Coatesville for completion in offshore, SAR, VVIP and utility configuration.

“The transition to Coatesville for the commercial product was a natural fit,” said Audrey Brady, general manager of the Coatesville factory, who was previously the S-92 program director. “We began by completing the assembly of the 115th S-92 and progressed to full assembly by the time we completed the 127th aircraft.”

The Coatesville facility employs more than 500 people and covers more than 416,000 square feet, including the 217,000 square feet Heliplex where Sikorsky commercial assembly lines and well-equipped production test flight and delivery center are located.

Like most modern aircraft factories, Coatesville is a system integrator of large aircraft sub-assemblies made elsewhere in the world. Sikorsky makes the S-92's rotor and dynamic system in the United States, but all the major airframe components are made by risk-sharing partners around the globe.

Embraer in Brazil produces the S-92's sponsons and its subsidiary ELEB makes the landing gear; AVIC subsidiary Changhe Aircraft in China makes the tail rotor pylon; Tata Advanced Systems in India makes and assembles the cabin; Aerospace Industrial Development Corporation in Taiwan makes the cockpit; and Aernnova of Spain makes several metal and composite components (including the rear fuselage, aft transition tailcone, horizontal stabilizer, engine cowlings, main rotor pylon, and cargo ramp).

Sikorsky has a two-step sales process where customers accept delivery of a “green” aircraft, which are then sent to the completion hangar for customization prior to final delivery.

“We build a vanilla aircraft and every S-92 that comes off our production assembly line is exactly the same,” Brady told *Vertical*, adding that the variations to the wiring packages to accommodate new

Beginning in 2015, Bristow assumed responsibility for search and rescue operations within the United Kingdom on behalf of HM Coastguard with a mixed fleet of helicopters that includes ten S-92s based at five different locations in the UK.

Sikorsky Photo



avionics and systems (such as SAR systems, TCAS II, ADS-B and Rig Approach) and options such as auxiliary fuel tanks are added during the completion process.

"Most of the aircraft we are producing are delivered in offshore configuration, but we also complete S-92s for VIP, VVIP, heads of state, search-and-rescue, and utility customers," she said.

One of the most challenging S-92 completions jobs was a November 2007 order for 15 multi-mission S-92s for the Saudi Arabian Ministry of Interior (MOI), with deliveries fast-tracked to begin as early as March 2008. The aircraft were highly customized to respond to critical missions in the kingdom, including SAR, firefighting, and EMS — in addition to security and traffic surveillance missions. And the aircraft had to be quickly configured for each mission. Despite the logistical challenges the order presented, the first S-92 was delivered on schedule.

FLYING IN THE GULF OF MEXICO

The offshore oil-and-gas industry has become the biggest market for the S-92, with Bristow, PHI and CHC flying large fleets in the Gulf of Mexico, the North Sea, Brazil, and Australia. The S-92 also flies with smaller companies providing transport to oil-and-gas fields in Azerbaijan, Brunei, Canada, China, Nigeria, Norway, Malaysia, Thailand, Trinidad, and the U.S.

As of June 30, 2016, Bristow had 76 S-92s in its fleet, CHC was operating 44 S-92s at the end of fiscal year 2016 (prior to its court-supervised reorganization), and PHI Inc. had 35 S-92s as of Dec. 31, 2015.

In the Gulf of Mexico — the region where the aircraft completed its first operational flight — Bristow utilizes the S-92 to deliver passengers and cargo to deepwater installations anywhere from 50 to 250 nautical miles (nm) offshore, according to Bob Old, the company's director of operations of the Americas region. "More common are flights in the 150 nm range," he told *Vertical*. "The biggest benefit for our clients is the passenger carrying capability. The ability to carry 19 passengers at a time makes client crew changes more efficient."

In this region, aircraft may need to fly through squall lines, and deal with bands of continuous rain showers, low ceilings and poor visibility. There is also the threat of tropical storms and hurricanes.

"We often utilize the S-92 to quickly evacuate workers from the larger offshore



MidContinent[®]
INSTRUMENTS+AVIONICS

Fly SAM[®]



2-inch attitude, altitude, airspeed and slip.

SELECTABLE ORIENTATION



SAM[®], the MD302 Standby Attitude Module, is the first digital standby to display attitude, altitude, airspeed, slip, vertical trend, and heading information in an advanced, 2-inch format.

FIELD UPGRADEABLE SOFTWARE

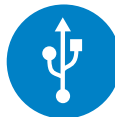

SAM delivers an easy-to-fit, compact design with selectable orientation (horizontal and vertical) like no other, ensuring a perfect fit within any panel. SAM's unique, two-screen display features high-definition graphics and extra-wide viewing angles. And at 1.6 lbs., SAM weighs less than the three instruments it's designed to replace. Get to know SAM, today.

LITHIUM-ION EMERGENCY BATTERY



FLYSAM.COM





The S-92 high visibility cockpit features Rockwell Collins Pro Line 21 avionics with four LCD displays and space in the center for an optional fifth panel for offshore or SAR use. **Ahmed Al Hader Photo**

structures in advance of these storms, because of the aircraft's large size and ability to accommodate 19 passengers at a time," said Old. "In the Gulf we also have to operate in hot summer temperatures. One of the many high points of the S-92 is that it is air-conditioned so passengers are comfortable in flight even on the hottest days."

Bristow customizes the cockpits of its S-92s in the Gulf with an optional fifth multi-function display to enhance pilot visibility, and these are well-liked by flight crews.

In 2008, VIH Cougar introduced a dedicated SAR S-92 to the Gulf of Mexico on contract to two major international oil companies. Equipped with both a SAR and EMS interior, it was one of the first helicopters on the scene when the drilling rig Deepwater Horizon exploded on April 20, 2010.

Chevron USA introduced its first offshore S-92 in 2013, and three of the aircraft are now stationed at its new centralized base in Galliano. Chevron is the only major oil company in the Gulf of Mexico that operates a large fleet of helicopters and also contracts helicopters from commercial operators.

In 2015, Era Helicopters took delivery of its first two S-92 helicopters — the first in the world to feature Sikorsky's gross weight expansion (GWE). The first of these entered revenue service in October, flying from Era's new "super base" in Houma, Louisiana.

"The extra 1,200-pound payload capacity provides enhanced flexibility that benefits the customer," said Paul White, Era's senior vice president, commercial. "Our S-92s can carry more passengers and we can take them further, with minimal fuel stops."

PHI's busiest S-92 base is at Louisiana's Houma-Terrabonne Airport. It has two separate passenger terminals and heliports dispatching S-92s offshore, including one dedicated to BP.

OFFSHORE CANADA

Cougar Helicopters was the first offshore operator to order the S-92, but the third to put it into revenue service as it needed to wait for Transport Canada certification of the S-92's innovative Rotor Ice Protection System (RIPS). The RIPS works by determining the temperature and moisture content of the surrounding environment and automatically applying heat to the main and tail rotor blades to remove any ice build up.

Rick Burt, vice president of offshore and SAR at HNZ Group (and a former offshore executive with CHC and Cougar) was the first offshore pilot to fly the S-92 and publish a flight report in a helicopter magazine in 2001. "My first impression was that the S-92 was a new generation helicopter that could carry twice as many passengers per flight between St John's [Newfoundland] and the Hibernia, Terra Nova or White Rose oil fields Cougar served that were located between 170 and 200 nautical miles offshore," Burt told *Vertical*.

The first Cougar S-92 flew offshore on April 7, 2005. "The S-92 introduction was quite a big change for our company," said Paul Carter, Cougar's chief pilot. "The passengers adapted very quickly because they could stand up in the aircraft and the seats were comfortable, but it took a while for our pilots to transition from a Super Puma with 'steam gauge' instruments in a cockpit designed in the 1980s to the glass panel cockpit of the S-92. We were used to looking at a few gauges and now we had a tremendous amount of information sitting on the screens in front of us. But by the second or third year, you really formed a love for the aircraft."

Cougar contracted VIH Aerospace to develop a 150-US gallon (570-liter) auxiliary tank for work that went beyond 200 nautical miles. Each tank provides an additional 45 minutes of flight.

Cougar was the first operator — civil or military — to utilize the

SETTING THE STANDARD OF CUSTOMER SERVICE

Time for an engine check-up?

Vector Aerospace is just what the doctor ordered!

We prescribe the following to get your Rolls-Royce M250 engine back up and running:

- Engine and module repair and overhaul
- Borescope inspection
- Failure analysis
- Component repair
- Foreign Object Damage (FOD) repair
- Model conversions
- Increased engine performance
- Complete test capabilities
- Rental pool available
- Parts support
- Engineering support
- Service Bulletin (S/B) compliance
- Worldwide field service

Need a spoonful of sugar to help the medicine go down?

For a LIMITED TIME we are offering a discounted hourly rate of \$85 USD (\$115 CAD) for all operators PLUS all rentals at Direct Operating Cost (DOC).

*Offer valid for units received before September 30th, 2016.
Estimate must be approved within 15 days of submission.

Vector Aerospace is a Rolls-Royce M250 Authorized Maintenance Repair and Overhaul Center (AMROC), and a Rolls-Royce M250 authorized Repair & Overhaul center for fuel accessories including: bleed valves, fuel pumps, fuel nozzles, and fuel controls.

CONTACT US

www.vectoraerospace.com | Toll Free: 1.888.729.2276

VECTOR
A E R O S P A C E

S-92 for SAR, and its aircraft is now compatible with night vision goggles. VIH Aerospace designed and built a SAR equipment installation that has an LCD display screen, communications suite, controllers for an infrared camera and NightSun searchlight, and a "Sea Tray" to protect the cabin floor from seawater.

The newest installation in the SAR aircraft is a GoPro camera mounted externally to capture the hoist sequence.

A new CAE Level D full flight simulator in Mt. Pearl was certified on March for training on March 25 this year. Cougar pilots are required to do three night offshore takeoffs and landings in a simulator every 90 days, and spend two hours in the simulator every three-week shift.

In the fall of 2014, CHC Helicopter Canada Inc. put three S-92s into service supporting Statoil's West Hercules rig drilling in the Flemish Pass Basin.

"We were flying 284 nm offshore Arctic during the drilling of the Cupids well program, but due to extreme Arctic conditions creating ice, the rig moved to a distance of 295 nm for a week during the 700-day operation," said CHC's Brian Bianco. "CHC is proud that its S-92s have conducted the longest flights to an offshore rig anywhere in the world."

In good weather, the S-92 could carry between five and eight passengers to the world's most distant platform.

In mid-October 2015, HNZ Group (formerly Canadian Helicopters), became the third Canadian offshore operator of the S-92 when it began flying for Shell Canada to deepwater drillship Stena Icemax. The contract included a crew change S-92 and a dedicated SAR S-92 with a back up aircraft that could fill either role.

THE CHALLENGE OF THE NORTH SEA

Today, four operators — Bristow, CHC, Babcock Mission Critical Services Offshore Limited and Norsk Helikopterservice (NHS) — fly a combined fleet of almost 90 S-92s in Europe, including 16 on

government SAR contracts in the UK and Ireland. During the summer, additional crew change and SAR S-92s arrived in the U.K. and Norway from overseas to fill in for the grounded H225 fleet.

Historically, Aberdeen handles 500,000 offshore helicopter passengers a year flying primarily in S-92s and H225s. The recent H225 grounding has altered the picture on the ground and in the sky, with hundreds of people working behind the scenes to keep passengers flowing without disruption to the offshore platforms.

On April 29, 2016 — the day of the Turøy crash — there were 95 offshore movements at Aberdeen Airport flown by 26 different helicopters (13 H225s and 13 S-92s), according to an air traffic monitoring program. On Aug. 26, there were 125 offshore movements flown by 26 helicopters (one AW139, two H175s and 23 S-92s). Between the two sample periods, the S-92 fleet at Aberdeen increased by 77 percent and S-92 movements increased by 135 percent.

The aircraft made its debut in the region with Norway's Norsk Helikopter in February 2005. Utilization of the aircraft soon reached eight to nine hours a day, and the first S-92 reached 1,000 flight hours within seven months.

CHC Helikopter Service of Norway, part of the CHC Group, became the second operator of the S-92 in the North Sea in 2005.

"Our pilots and crews appreciate the modern cockpit, flight control system with auto-hover, medical kit options and storage space," said Dave Balevic, SVP of engineering and operations at CHC.

CHC launched the first S-92 flights serving the U.K. sector of the North Sea from Aberdeen Airport (the world's busiest offshore oil hub) in 2006. The next year, it placed the world's first dedicated SAR S-92 in service when four aircraft began a five-year Maritime and Coastguard Agency (MCA) contract in northern Scotland.

(Today, Bristow operates 11 S-92s as part of a fleet of 22 aircraft providing SAR services on behalf of the MCA in the U.K.)

As regulators and industry introduced new offshore safety

Cougar was the launch customer for the S-92 in 2000, but was the third customer to introduce the S-92 into service when it began operating off the east coast of Canada in 2005. Cougar was also the first customer to utilize the S-92 in a search and rescue role. **Mike Reyno Photo**



The Sikorsky CH-148 Cyclone maritime helicopter entered Royal Canadian Air Force (RCAF) service in June 2015. A major technological advancement over the CH-124 Sea King, the multi-mission Cyclone features fly-by-wire flight controls, more powerful GE CT7-8A7 turboshafts, multiple sensors, an integrated mission system and a maximum takeoff weight of 29,300 lb. — 2,800 lb. more than the civil S-92A. **Mike Reyno Photo**



Era Helicopters introduced its first S-92 — the first in the world to feature Sikorsky's gross weight expansion — to clients in the Gulf of Mexico in October 2015. **Dan Megna Photo**



HNZ Group's S-92s fly from Halifax, Nova Scotia, for Shell Canada. **Kenneth I Swartz Photo**



“ From a mechanic’s perspective, I am yet to talk with an engineer who does not like working on them. The ease of maintenance, reliability and actual access to components make it a mechanic’s dream.”

requirements in the North Sea, the S-92 received further enhancements. In mid-2012, the FAA and the European Aviation Safety Agency (EASA) certified it for Sea State 6 conditions, completing the S-92A emergency flotation system sea state expansion.

A GLOBAL MARKET

Brazil is the largest offshore oil producer in South America, and the country received its first S-92s in late 2009. Today, the S-92 now flies with the three largest offshore operators: Lider TÁxi Aéreo S/A, BHS – Brazilian Helicopter Service TÁxi Aéreo Ltda, and Omni TÁxi Aéreo Ltda.

Lider is Brazil’s largest helicopter operator and Latin America’s largest business aviation enterprise. It introduced the aircraft to the region, and has 12 S-92s in current service.

“The S-92 has been extremely significant to the growth of Lider because it became the backbone of our contribution to the exploration of pre-salt areas for Petrobras,” said Eduardo Vaz, Lider Aviação CEO, adding that the S-92 offers “first and foremost, safety and reliability . . . and superb operational capabilities giving . . . the range, payload, and speed Petrobras needs.”

Elsewhere, the S-92 has helped develop oil and gas fields off the coasts of Malaysia, Brunei, Australia, China, and Thailand.

Thai Aviation Services (TAS) introduced the S-92 into its fleet in 2013. “The S-92s replaced two S-61Ns serving offshore rigs between 90 nm and 150 nm offshore,” said Craig Havas, TAS’s deputy managing director – operations, and S-92 chief pilot. “For the pilots, the new technology translated into significant flight safety improvements and better operational capability. From a mechanic’s perspective, I am yet to talk with an engineer who does not like working on them. The ease of maintenance, reliability and actual access to components make it a mechanic’s dream.”

Sikorsky took a risk when it launched the S-92 in 1995, but 20 years later, the helicopter continues to find new civil and military customers and promises to be in service for a long time to come.

Ken Swartz | An award-winning helicopter industry journalist who has covered the market for 35 years, Ken has spent most of his career as an international marketing and media relations manager with airlines and a leading commercial aircraft manufacturer. He runs Aeromedia Communications, a marketing and PR agency, and can be reached at kennethswartz@me.com.

KAMATICS



ENGINEERED PERFORMANCE Flexible Drive Systems and Couplings

For close to four decades, our maintenance-free flexible drive systems and couplings have been the first choice for helicopter main-shaft and tail rotor driveline locations; applications where failure is not an option.



www.kaman.com/engineered

KAMAN
Specialty Bearings &
Engineered Products

P&WC Photo



Safran Helicopter Engines Photo



2016 Helicopter Engine Survey

In our first-ever Helicopter Engine Survey, we asked readers to tell us what helicopter engine manufacturers are doing right — and what they can do better. Here's what you had to say.

Story by Elan Head | Data analysis by PMG Intelligence



Rolls-Royce Photo



Lycoming Photo



Honeywell Photo



When we launched our annual Helicopter Manufacturers Survey last year, our goal was simple: we wanted to create a comprehensive customer satisfaction survey by the helicopter industry, for the helicopter industry. We were thrilled with the number of our readers who took the time to share their opinions with us, providing a truly representative overview of what the airframe original equipment manufacturers (OEMs) are doing right, and what they can do better.

Earlier this year, we ran our Helicopter Manufacturers Survey for the second time (see p.70, Vertical, June-July 2016). But we also decided to expand our efforts by launching another survey focused solely on helicopter engine OEMs. Powerplants are, of course, vital to keeping helicopters flying. When it comes to avoiding costly downtime, the support provided by engine OEMs can be as crucial as the support provided by aircraft manufacturers themselves.

While most pilots have strong opinions about the aircraft they fly every day, the people who are most knowledgeable and opinionated about engines tend to be maintenance personnel, more experienced pilots, and the people writing the checks. So we expected that the total number of respondents for our engine survey would be lower than for our airframe survey.

It was, but we still had a very strong response, with 260 respondents completing a total of 463 evaluations (since many respondents evaluated more than one engine OEM). Nearly half of our respondents (49 percent) have been employed in the helicopter industry for 20 or more years, while fully 80 percent have been in the industry for 10 or more years. Between them, that's an incredible amount of experience, and

we feel confident that the OEMs should be listening to their opinions.

Fortunately, they are. As with our airframe survey, we asked engine manufacturers to respond to the specific concerns our commenters mentioned most frequently, and you can read their detailed responses on the following pages.

In determining an overall ranking, we compared the manufacturers' scores across all measures, which were generally consistent with the numbers you see here — the averages of scores for "overall service satisfaction" and "overall engine/product satisfaction." Pratt & Whitney Canada (P&WC) was the clear winner in our survey (although General Electric might have been a strong challenger if it had received more evaluations. We set a minimum number of 45 evaluations for inclusion in our ranking; GE received only 18).

While P&WC earned top honors, Safran Helicopter Engines finished a relatively strong second, doing particularly well when it came to the quality and responsiveness of its field representatives. Note that, although we have included Lycoming in our overall ranking for comparison purposes, as the only piston-engine manufacturer in our survey, it serves a different market than the turbine-engine OEMs.

When we repeated our airframe OEM survey earlier this year, we saw some significant changes in the landscape of rotorcraft customer support, and those between-year comparisons said a lot about where OEMs are investing their resources in a tough economic climate. With that in mind, we look forward to continuing to track the engine manufacturers' performance in years to come — and providing them with meaningful feedback on how to improve their products and services.

Overall Ranking



Mean scores for 'overall service satisfaction' and 'overall engine/product satisfaction' on a scale of 1-5, where 5 means 'excellent' and 1 means 'poor'

PRATT & WHITNEY CANADA



Pratt & Whitney Canada (P&WC) was the hands-down winner of our survey. It ranked first across most measures (and not lower than second on any), and was first in “overall service satisfaction” and “overall engine/product satisfaction.” It scored particularly well relative to the other OEMs when it came to “AOG [aircraft-on-ground] service.”

Despite its dominant performance, P&WC isn’t resting on its laurels. “At P&WC, we are driven by the concept of continuous improvement,” the company told us. “It’s gratifying that our operators have ranked us so highly, but we never stop trying to do better.”

P&WC highlighted a number of recent steps it has taken to improve customer support, stating, “Planned and preventative maintenance is a priority for our operators and for us. We are at the forefront of advanced diagnostics and prognostic technologies. Our FAST [Flight Acquisition, Storage and Transmission] solution is installed on more than 600 P&WC powered aircraft, downloading 120,000 files per month. Our Oil Analysis Technology Program continues to build momentum as a next-generation on-wing monitoring solution for preventative maintenance. We have more than 2,000 engines enrolled in our customer trial.”

The company noted that it has also invested heavily in its front-line support. “Our ‘first call’ resolution rate now consistently surpasses 80 percent and first-call technical recommendations are delivered in less than one hour,” P&WC told us, adding that it has completed the progressive rollout of its new service portal, “MyP&WCPower,” to more than 20,000 users, and transformed and enhanced its warranty services to increase the speed and agility of claim processing. The



company also reported that it has added 100 new rental engines to its already large rental engine inventory, which now includes 850 engines worldwide.

Although P&WC’s customers have clearly appreciated these efforts, one of our respondents suggested that “competitors are gaining ground in innovation and cost control programs.” So, we asked the company to address its current and future initiatives in these areas.

“Actually, reducing operators’ direct maintenance costs has long been a priority for us, and we are using innovative thinking to help achieve that,” P&WC told us. “We have recently introduced a suite of specialized maintenance programs under our P&WCSMART portfolio, including nine offers especially tailored for helicopter engines. These offers simplify engine maintenance and extend the life and value of the aircraft while reducing operators’ direct maintenance costs. Offers include engine upgrades, exchanges, flat-rate overhauls and more.

“As a testament to the program’s value, the number of customers has more than tripled in the past 12 months and transactions have doubled. Given that guaranteed pricing is a business imperative for

operators, P&WC will continue to grow our P&WCSMART portfolio and customer adoption is expected to more than double in the next 12 months.”

The company also pointed to some specific cost-saving achievements, including reducing the basic time before overhaul (TBO) for PW210 engines by 500 hours (representing a 10 percent cost savings for customers); extending the basic TBO for the power section of the PT6B-37A by 50 percent; extending the clutch inspection interval for the PT6T-9 engine by 60 percent; and increasing the fuel nozzles inspection interval in the PW206/PW207 engine family from 800 to 900 hours.

Finally, our respondents had positive things to say about P&WC’s commitment to safety — which goes hand-in-hand with overall engine satisfaction. As the company explained, “For us, safety is all about the reliability and dependability of our engines. Dependability is integral to our brand and we never forget that the engines that power our operators’ aircraft bear our name. P&WC engines are among the most reliable in the world. . . . P&WC is driven by a belief that nothing should fail.”

Action Time of Manufacturer

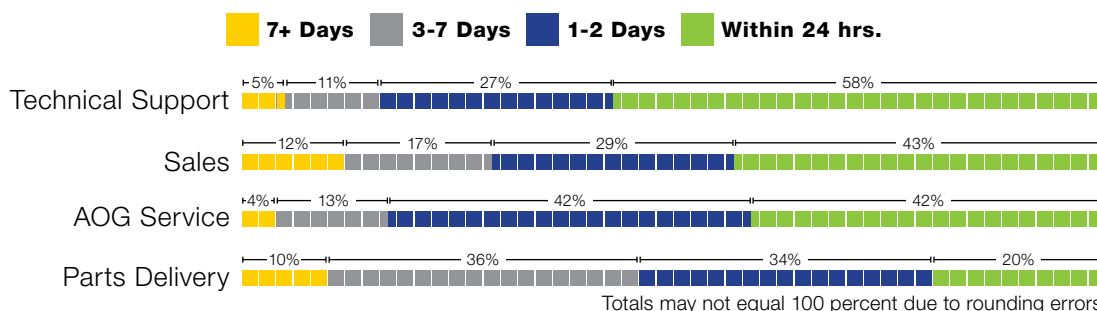

“PWC would benefit from being recognized for technical innovation and customer partnering to reduce operational costs. They have a strong reputation for product support but competitors are gaining ground in innovation and cost control programs.”

SAFRAN HELICOPTER ENGINES



Bell Helicopter Photo

The company previously known as Turbomeca had a strong showing in our survey, ranking second across many measures as well as overall. It ranked first in terms of “commitment to product improvement,” and tied with Pratt & Whitney Canada for first place in “warranty fulfillment.” But where Safran really stood out was in “responsiveness of service representatives” and “quality of field representatives.” It scored much higher than any other OEM on both measures, and our respondents singled out many individual Safran service reps for specific praise.

We asked Franck Saudo, Safran Helicopter Engines’ executive vice president of support and services, to comment on these strengths. He told us, “‘Focused on you’ is our commitment with a single objective: keep our clients flying. Fourteen front offices around the globe are dedicated to customer support and endeavor to provide the best of the best in terms of services. And we believe that it all starts with responsiveness. Our service representatives and the technical expertise of our field representatives are key elements to support our customers in their daily operations.

“Beyond this proximity-based focus, we believe in a ‘listen first’ approach that we deploy during dedicated events,” Saudo

continued. “During these events, Safran Helicopter Engines listens to actual customer issues early that need to be addressed. Be they product or service-related, dedicated resources and budgets are allocated to overcome these concerns through a prioritized process called the ‘TOP 5 customer irritants,’ followed closely by our top executives. We are proud that product improvement and warranty have received high scores as these two fields have been focused upon in the TOP 5 irritants.”

Despite these strengths, Safran had some notable weaknesses, too, ranking last among the OEMs when it came to “cost of parts” and “cost of overhaul.” Saudo said that improving direct maintenance and operational costs are main priorities for the company, and he pointed to some recent achievements in these areas. For example, since 2015, the time before overhaul of the Makila 2 engine has been pushed up to 4,000 hours, the Arriel 2S2 up to 3,850 hours, and the Arrius 2B2 hydro-mechanical metering unit (HMU) up to 3,850 hours. Reliability has also improved, with the Arriel 2’s mean time before failure increasing 25 percent since 2013, and the Makila 2’s mean time before unscheduled removal up 50 percent since 2011.

Saudo said that Safran is working to

reduce maintenance burdens by simplifying and lightening the maintenance programs for the Arrius 2F, Arrius 2B2, and Arriel 1D1. The company is also pursuing innovative manufacturing processes such as 3D printing, and new repair schemes. “Arrius 2B2Plus has already benefited from these efforts, leading to maintenance costs 20 percent lower than competitor engines,” Saudo noted.

Other projects aimed at strengthening the company’s industrial performance and optimizing its supply chain are also starting to pay off, he said. The company’s 24-hour aircraft-on-ground (AOG) service rate is now at 98 percent for the fourth consecutive year, and its spare parts service rate is over 95 percent for the third consecutive year, with the routine delivery time reduced to five days. Meanwhile, average repair turnaround times for the Arriel and Arrius are now at 65 days — a 30 to 35-percent reduction since 2013 — and the repair service rate for engines, modules, and equipment is now above 90 percent. The availability of the company’s pool has increased to reach an on-time dispatch rate of 98 percent for engines, full authority digital engine controls (FADECs) and fuel pumps (fuel control units and HMUs).

“Moreover, in a continuous effort to provide all our customers, whatever their fleet size, with the best support, we invest a lot of resources into expanding our network of certified maintenance centers and distributors,” Saudo said. “Over the past three years, this network has increased by 40 percent and counts now more than 40 partners worldwide, serving customers as closely as possible to their operational bases. A dedicated service offer, called ‘5Star Plans,’ has also been launched to answer the needs of operators who have less than five aircraft.”

Action Time of Manufacturer

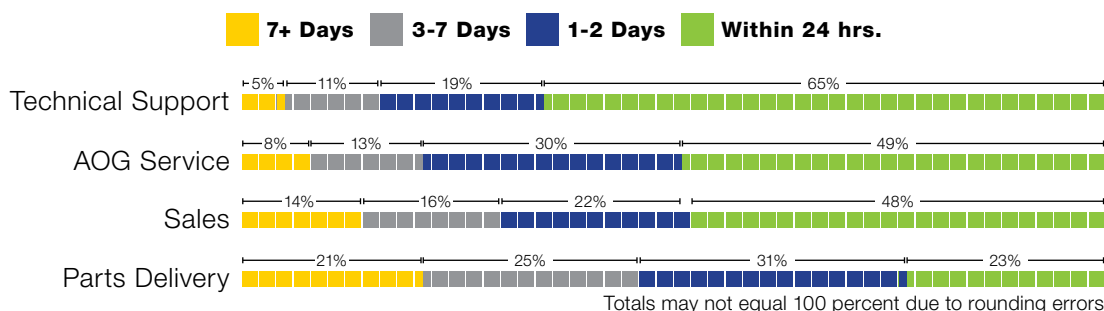

“Safran Helicopter Engines has had a gradual and steady improvement in their customer service and responsiveness. Many operators consider them to be as strong as some of the traditional leaders in customer support.”

ROLLS-ROYCE



Rolls-Royce ranked third across most measures of our survey, as well as third overall. It did particularly well in terms of “cost of overhaul,” ranking first among all OEMs. Other notable strengths included “satisfaction with authorized service centers” and “quality of technical publications,” where it came in second behind Pratt & Whitney Canada.

“Our commitment to our customers extends far beyond engineering a reliable engine, and we strive to always deliver best-in-class aftermarket support through Rolls-Royce approved M250 and RR300 FIRST networks,” the company told us. “Having an independently owned global network offers more local, competitive environments. Freedom of choice is a positive for our customers.”

However, the company did less well on measures of “commitment to product improvement,” “warranty fulfillment,” and “overall engine/product satisfaction.” Many respondents expressed concerns relating to reliability, with one commenting, “[Rolls-Royce] has not fully addressed all of their engine reliability problems, some of which have existed for years. The community perception and [Rolls-Royce’s] inability to completely address reliability issues is impacting operator/owner buying choices.”

Another commenter suggested that Rolls-Royce “institute a manufacturer-controlled oil analysis program and historical database tracking for forecasting failures and overhaul periods.”

In response to these concerns, the company told us, “Rolls-Royce continues to significantly invest in its wide range of engine portfolio of products. Over the past several years, we have enhanced many components of our engines to meet customer reliability expectations.



Skip Robinson Photo

We have introduced new bearings, oil lubrication systems, turbine wheels and entire new FADEC [full authority digital engine control] systems. On some of our more popular engine models, we have introduced performance and fuel consumption enhancements as well. These enhancements have been well received.”

With respect to an oil analysis program, however, the company said, “We have reviewed this issue several times over recent years. While the concept appears to have merit, there are so many variables with each aircraft application and its filtration system. We have determined that any benefit obtained would be outweighed by the high potential of increasing direct operating costs — which would not be beneficial for our customers.”

Several commenters mentioned that

they would like to see wider application of Rolls-Royce’s new-generation engines, the RR300 and RR500. So, we asked the company for an update.

“We are most pleased with the performance and reliability of the RR300 engine in the Robinson Helicopter R66 aircraft. Rolls-Royce purposely built the RR300 for the R66 helicopter — and now customers are experiencing the benefits from two great, innovative companies. Earlier this year, we announced a second RR300 platform with the Innova Helicopters’ C630 helicopter. This program is well under way as both Innova Helicopters and Rolls-Royce work toward first flight in 2017. The RR500 program was paused several years ago, though we continue to have conversations with customers about their needs.”

Action Time of Manufacturer

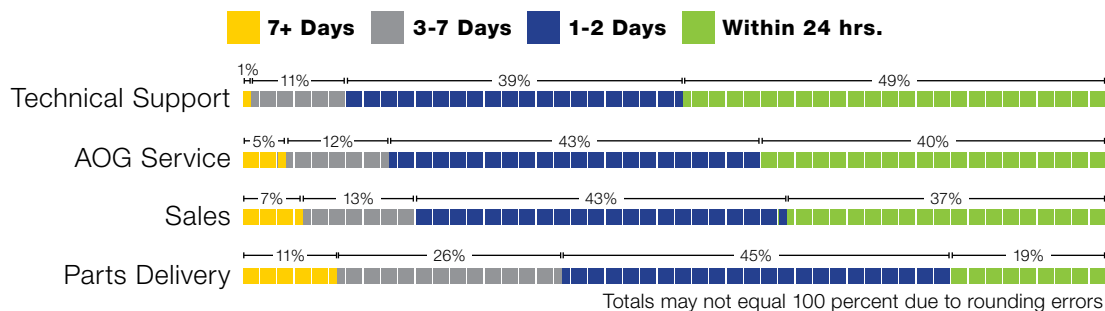

“Work with operators on known issues and warranty parts they know are defective and have a high removal rate.”

“Improve/advance the existing 250 series engines, or apply the RR300/500 to new applications and retrofits.”



StandardAero

Service related expenses are a significant part of an operator's bottom line.

At StandardAero, we're lowering our customers DOCs by implementing preventive practices that reduce unscheduled engine removal and emergency maintenance. As an OEM authorized Rolls-Royce AMROC, our comprehensive support programs are designed specifically to increase M250 MTBR, keeping you in the air with worldwide Service Centers and Mobile Service Teams available 24/7/365.

AOG and need it now? We have an extensive M250 engine and accessory exchange pool, supported by our fresh M250 rental fleet and fast turn times.

Please call or visit us online and discover how our 40+ years of M250 MRO experience can help increase *your* bottom line.

**SAVING YOU
MONEY IS OUR
BOTTOM LINE**

standardaero.com/heli

1.204.318.7544

LYCOMING



As the only piston helicopter engine manufacturer in our survey, Lycoming is really in a class by itself. Although we included it in our ranking to provide a relative measure of its customers' overall satisfaction, many of our respondents who evaluated Lycoming had specific concerns that weren't particularly relevant to the other, turbine engine manufacturers.

Lycoming received its highest score in the area of "parts availability," and it led all other OEMs on this measure. It also ranked first among the OEMs with respect to "cost of parts." When we asked the company to comment on how it makes sure customers have the parts they need, Lycoming explained, "There are two key parts to our success in this area. First is making certain the factory is running well and delivering product to our distributors with predictable response times. Second we work very closely with our global distribution network to make genuine Lycoming parts available to customers. We insist that our distributors understand the customer needs in their service areas and stock our parts accordingly. Lycoming utilizes many metrics to monitor the various processes that enable us to get the right parts, to the right place, at the right time."

Speaking of "genuine Lycoming parts," one respondent questioned why Lycoming has made a 200-hour time before overhaul (TBO) extension contingent upon using Lycoming parts. The company explained, "FAA-approved PMA [parts manufacturer approval] parts may vary from genuine Lycoming parts in ways for which Lycoming has not tested or accounted for when determining our TBO and other maintenance advice. Our recommendations are based on testing and field experience using genuine Lycoming OEM parts. Thus, once a non-OEM origin

part enters the equation, our TBO and other maintenance recommendations may not be relevant."

Although our respondents were generally happy with Lycoming's parts availability, they expressed a strong desire for more product development. Lycoming ranked last among the major OEMs when it came to "commitment to product improvement." Numerous commenters wanted to see Lycoming move away from magneto ignition systems, and otherwise "get in the 21st century with technology."

In fact, Lycoming has been very active in developing new engines recently — those products just haven't made it to the conventional helicopter market yet.

"Over the past several years Lycoming has actually launched many new products and introduced more new technology than [at] any time in our recent history," the company explained to us. "The 'flagship' Integrated Electronic Engine, known as the iE2, the Diesel cycle DEL-120 and the tiny EL-005 are just some of the examples of completely new engines flying today. You'll find iE2 engines flying on the Evolution and Tecnam P2012 Traveller aircraft today. The DEL-120 and the EL-005 power were introduced first on UAV [unmanned aerial vehicle] applications.

"The challenge, though, with new engines is that the aircraft needs to be recertified as well. That's mainly the reason why our newest and most sophisticated technology is showing up first in newly certificated, experimental and UAV aircraft. The task to re-engine an already certified aircraft is not insignificant; however, it does happen and we work closely with the airframe OEMs who ultimately make the call on which engine technology is approved on the aircraft."

In the meantime, the company said, it

is working "continuously and quietly to incorporate improvements at the component level for our legacy aircraft engines. Virtually all of the component improvements we make are targeted toward improving the durability of the engine and thus reducing maintenance costs for consumers. Our materials laboratory is one of the most capable of its kind in aviation, and we leverage it extensively in introducing the new component technology that is core to how genuine Lycoming OEM parts perform."

GETTING THE LEAD OUT

One survey respondent questioned whether the new 100LL avgas replacement now being developed by the U.S. Federal Aviation Administration (FAA) and industry will work in Lycoming's legacy engines, so we asked the company for an update. Lycoming noted that Phase 1 of this Piston Aviation Fuels Initiative has been completed, narrowing down the candidate fuels to two options from two manufacturers, Swift and Shell Aviation. Phase 2, which is focused on full scale testing of multiple engines and aircraft, is currently underway.

"Lycoming's involvement with unleaded avgas has been extensive for decades," the company stated. "Quite frankly, we're looking forward to the transition as it opens doors for us on the technology front. Consumers will benefit as well, as unleaded avgas will reduce maintenance and consumables costs. There is a lot of elbow grease left to expend in the unleaded transition effort, but we're also highly confident that our current engines are going to run very well on the new fuel."

Action Time of Manufacturer

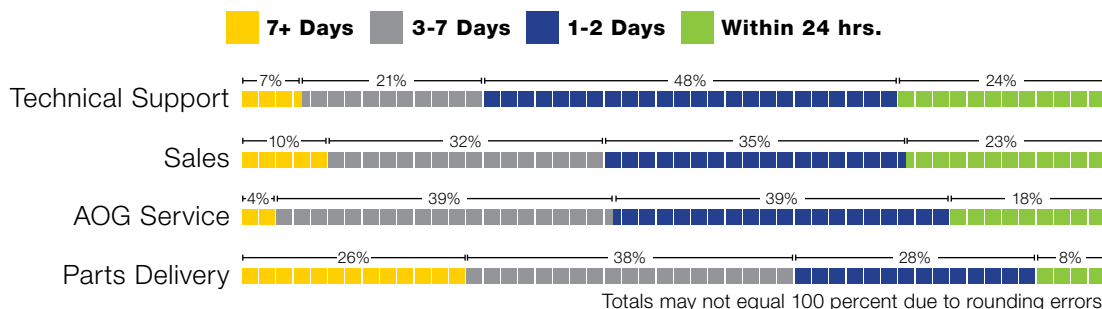

"Move away from magneto ignition systems."

"Increase rate of product development."

With dedicated AOG service (1-800-HELIMART)

We are your 24/7 global parts source for:

- MD HELICOPTERS
- AIRBUS HELICOPTERS
- BELL HELICOPTER
- SIKORSKY AIRCRAFT (LIGHT)
- ROLLS-ROYCE 250 SERIES ENGINES

heli-mart

ANY PART.

ANY TIME.

ANY PLACE.

helimart.com

714-755-2999

Toll Free US/CAN 800-826-6899



HONEYWELL



Honeywell ranked last in our survey across many measures, and for both overall service satisfaction and overall engine/product satisfaction. However, most of the respondents who evaluated Honeywell in our survey had experience with only older legacy engines, such as the T-53, which dates to the 1950s and was originally manufactured by Lycoming. We only received eight evaluations from respondents with experience with the new-generation HTS900 engine, so Honeywell's overall ranking and scores should be viewed with that in mind. All things considered, Honeywell did relatively well in terms of "commitment to product improvement," coming in third among all OEMs.

We asked Doug Kult, Honeywell's director, Light Helicopter Engines, to speak to some of the challenges associated with supporting these legacy engines. "The main challenges . . . are maintaining the supply of spare parts, managing spare parts cost, and keeping manuals updated," he said. "In addition, we focus heavily on managing and correcting field related problems, developing fixes, and developing component repairs to keep

operating cost as low as possible."

Kult said that the Honeywell team remains focused on a strategy that was laid out four years ago, which aims to fix all operational and field issues, increase engine performance where possible, and reduce engine operating cost. He noted, "Each year at the Honeywell Operators Conference prior to Heli-Expo, I present to the operator community our goals for the year as well as our hits and misses from the prior year. We've also developed an annual operator focus group to measure how we're doing. So far, we have fixed the majority of the legacy field issues and have lowered operating cost by 20 percent."

One of our respondents observed that, "Honeywell leadership is fragmented in their approach to the customer, and at times seems confused regarding its commitment to the helicopter market." In response, Kult told us, "I understand that some customers may have this perception; over the last few years Honeywell has implemented several changes to the past way of doing business and we've experienced some growing pains. I believe these have been worked out

and our helicopter engine customers are getting the attention they need to run their business profitably using our products. We discuss this each year during our Honeywell Operators Conference to ensure that our customers know how to approach Honeywell successfully."

On a more positive note, several of our commenters said they'd like to see the HTS900 available on more platforms, so we asked Kult for an update on that program.

"The HTS900 potential applications range from 5,000-pound light single engine helicopters to 9,500-pound medium twin-engine helicopters," he said. "It is currently certified on the Eagle 407HP helicopter that is achieving impressive performance gains for operators flying it. We have customers using this machine in Canada, the United States, and as far away as Papa New Guinea. In addition, we have two other single-engine applications approaching certification" (the Marengo Swisshelicopter SKYe SH09 and another platform that has yet to be announced).



Eagle Copters Photo

Action Time of Manufacturer

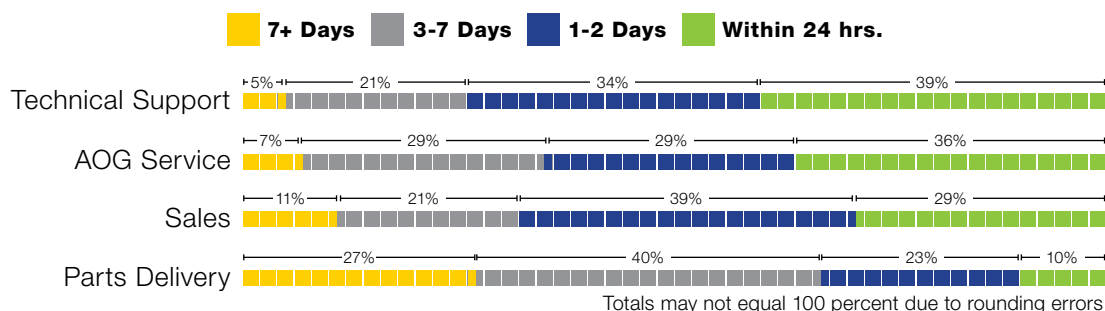

"Product support has fallen steadily in the last few years; give operators more options for engine repairs and parts."

"Speed the process of making product improvements and increased TBOs."



- FLIGHT PLANS
- FLIGHT FOLLOWING
- AVIATION FUEL
- WEATHER BRIEFINGS
- NOTAMS
- OVERFLIGHT & LANDING PERMITS
- GROUND HANDLING
- 24/7 DISPATCH

S K Y P L A N



Leave everything UP to us.

We exceed your expectations with flying colors.

The Aurora flight planning system lets you easily build, test, manage, visualize, file and uplink flight plans ANYTIME and ANYWHERE! Couple that with a fully integrated map that allows you to generate flight plans, retrieve tabular and graphic weather data and NOTAMS, and deliver flight plans using multiple communications networks.

Contact a Skyplan representative today and ask about our web-based Aurora flight planning system.

Suite 104, 7777 10th St. N.E., Calgary, Alberta, Canada, T2E 8X2
TEL +1 (403) 275-2520 • FAX: +1 (403) 275-3911 • TOLL FREE: +1 (800) 661-9189
E-mail: ops@skyplan.com • www.skyplan.com

TOP SERVICE REPS

We asked respondents to rank engine manufacturers on a wide range of measures, including “responsiveness of service representatives” and “quality of field representatives.” Because numbers don’t tell the whole story, however, we also gave respondents the opportunity to recognize specific outstanding service reps.

Safran customers were particularly enthusiastic about their service representatives, mentioning 11 specific field reps: Joe Braz, Josh Esquivel, Mike Evans, Rich Fulmer, Chris Mayer, Jason Mitchell, Russ Morris, Tom Pfeiffer, Robert Snow, Rob Soucy, and Chris Woosley. They also praised technical service representative David Ault, customer support manager

Tom Belew, and customer service representative supervisor Justin Rawlinson.

Other OEM service representatives who were singled out for recognition include Chuck Beaston, Thomas Brigham, and Scott Shepherd of GE; Roger Gibbs of Honeywell; and Greg Houston, Simon Kemp, and Jim Taylor of Rolls-Royce. Several respondents also mentioned Rolls-Royce’s Kevin Griggs, who retired in 2014 but whose continued recognition “is a true testament of Kevin’s great love for his customers,” as Rolls-Royce told us.

Our respect goes out to these and all of the other hardworking service reps who go the extra mile to keep their customers flying.

“ BOB SNOW AND TOM BELEW, SAFRAN

“Bob and Tom have gone above and beyond to help us with our engine needs. They understand that public agencies have a difficult and sometimes lengthy approval process, and they make sure those difficulties do not slow part shipments or overhaul times.”

“ ROGER GIBBS, HONEYWELL

“Always available to discuss everything from technical problems to publication issues and any other items relating to the LTS101. If not available to answer his phone, he always calls back ASAP.”

“ ALAN DILLEMUTH, SAFRAN

“His knowledge and experience [are] exceptional, and his dedication to timely support has guaranteed our agency can perform our mission. In my tenure of over 20 years of involvement with the helicopter maintenance industry, I have not met a better tech rep than Mr. Dillemath.”

“ CHRIS MAYER, SAFRAN

“Chris always provides great customer service. He responds within a reasonable time, with answers to tough questions.”

“ RICH FULMER, SAFRAN

“In the 16 years I’ve been flying Arriel-equipped AStars, Rich Fulmer has ALWAYS answered his cell phone to help solve problems. He’s honest and forthright about product shortcomings and works tirelessly to solve issues regardless of time zone or hour of the day/night.”

“ SIMON KEMP, ROLLS-ROYCE

“Superb contact and constant follow-up.”

“ SCOTT SHEPHERD, GE

“Scott is very knowledgeable on the GE engines and is always there to provide assistance to our operations.”

“ TOM PFEIFFER, SAFRAN

“Tom has assisted when issues arise day or night, [including] once at 2 a.m. on site to get the aircraft back in service.”

“ GREG HOUSTON, ROLLS-ROYCE

“Super knowledgeable, and gets back to the customer really quick.”

Your Helicopter Rotables Solution



Tired of dealing with large inventories and high-dollar carrying costs? Aviall's new Helicopter Rotables Program can help! We offer a pool of outright and exchange components for the Bell 204, Bell 205, Bell 206, Bell 212, Bell 412, Bell 407, MD500, Airbus AS350 and Sikorsky S-76. Let us help manage your repairs more effectively, reduce your administrative costs and minimize your inventory investment. Contact an Aviall Sales representative today! Go with Aviall.

PROUDLY KEEPING THE WORLD IN FLIGHT

aviall.com/helicopter | 1-770-473-1346

AVIALL
A BOEING COMPANY

METHODOLOGY

Our survey was conducted by PMG Intelligence, a market research and data analysis consulting company based in Waterloo, Ontario. PMG created a dedicated website for our survey, collected the responses, and performed all data analysis.

We distributed the survey link via email to subscribers on our *Vertical Daily News* email list. We also invited engine manufacturers to share the link with their customers, and promoted the survey through *Vertical's* social media channels.

The respondents were qualified through the process of initial questions directly related to the helicopter industry. If respondents did not indicate that they are currently employed in the helicopter industry, with recent operational or maintenance experience with specific helicopter engine models, they were redirected out of the survey and notified that they did not qualify. If respondents

disqualified on the survey, their IP addresses were marked and cross-referenced to ensure that they did not try to re-enter the survey. All responses also underwent a data cleaning process in which response patterns were validated to ensure the authenticity of results prior to analysis.

We asked respondents to supply their name and email address for further validation; however, all responses were kept completely anonymous. PMG only provided us with contact information for those respondents who indicated that they were willing to be contacted to discuss their comments, or receive a copy of the survey results.

Data collection took place in August 2016. A total of 260 respondents participated in the survey. We ranked only OEMs who received at least 45 evaluations.

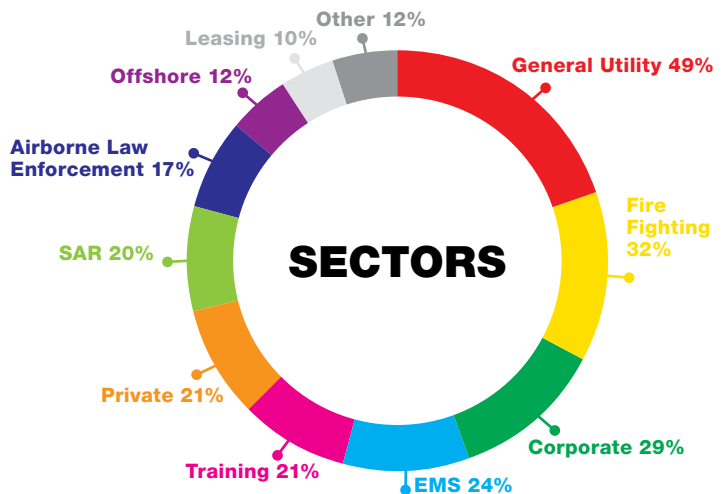
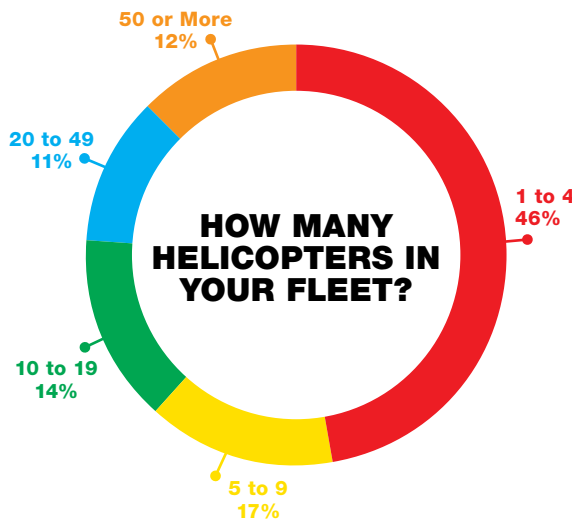
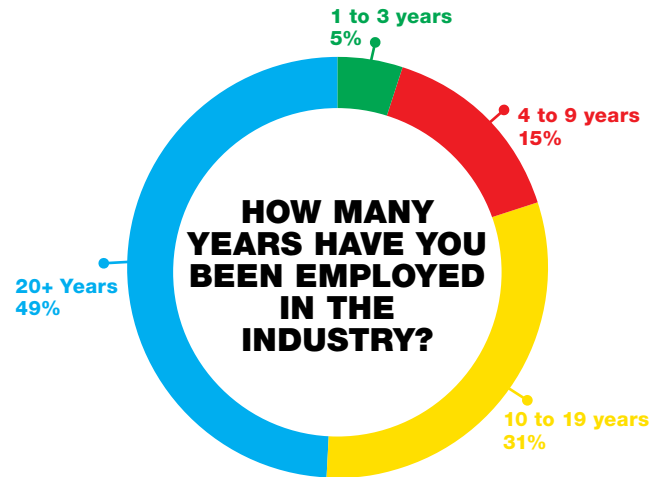
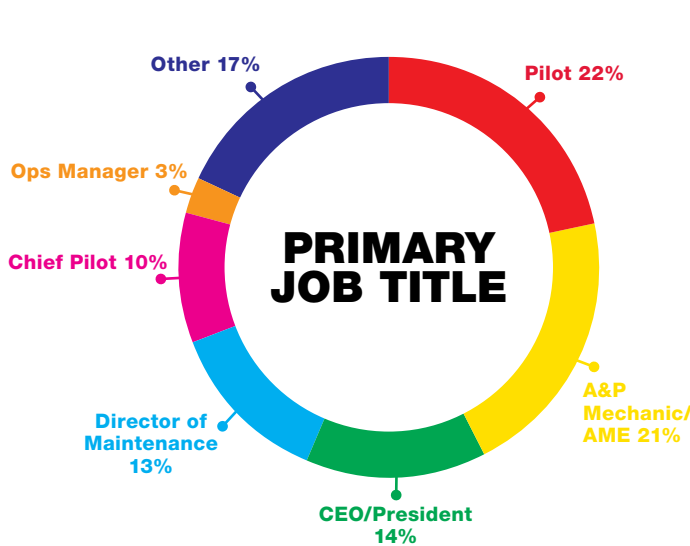

Many respondents indicated that they operate in more than one sector, so total is greater than 100 percent.

TANGO[®] WIRELESS HEADSET

THE **FIRST** PREMIUM **WIRELESS** AVIATION HEADSET



THAT'S RIGHT,
WE SAID **WIRELESS.**



WITH A FULL LINE OF PREMIUM ANR HEADSETS, LIGHTSPEED HAS A HEADSET FOR **EVERY MISSION.** LEARN MORE AT LIGHTSPEEDAVIATION.COM

ALL MEAN SCORES

	Pratt & Whitney Canada	Safran Helicopter Engines	Rolls Royce	Lycoming	Honeywell
Commitment to Product Improvement	3.88	3.91	3.19	3.18	3.40
Parts Availability	3.94	3.57	3.75	4.09	3.28
Cost of Parts	3.05	2.50	2.89	3.25	2.84
Cost per Hour Program	3.40	2.78	3.26	3.29	2.78
Cost of Overhaul	3.04	2.46	3.11	3.02	3.00
Warranty Fulfillment	3.76	3.76	3.44	3.62	3.44
Speed of Service Response Time	3.91	3.76	3.62	3.54	3.30
AOG Service	4.06	3.87	3.79	3.58	3.26
Responsiveness of Service Representatives	3.96	4.11	3.94	3.71	3.62
Quality of Field Representatives	4.00	4.20	3.91	3.56	3.68
Satisfaction with Factory-owned Service Centers	3.79	3.62	3.49	3.50	3.57
Satisfaction with Authorized Service Centers	4.05	3.71	3.96	3.79	3.53
Quality of Technical Publications	3.97	3.62	3.74	3.56	3.67
Quality of Product Training Provided	3.93	3.84	3.73	3.32	3.29
Quality of Maintenance Training Provided	4.04	3.97	3.80	3.55	3.21
Website Functionality	3.64	3.42	3.26	3.09	2.86
Overall Service Satisfaction	3.96	3.79	3.60	3.49	3.40
Overall Engine/Product Satisfaction	4.13	4.09	3.77	3.81	3.71

On a scale of 1 – 5 where 5 means 'excellent' and 1 means 'poor'

QUALITY

YOU CAN DEPEND ON WITH THE

SUPPORT

YOU CAN EXPECT



HID/IR SEARCH & LANDING LIGHTS
INNOVATING TODAY FOR TOMORROW'S SOLUTIONS

Luminator
AEROSPACE
An LTG Company

900 Klein Road, Plano, TX 75074 | Tel: 800.388.8205
aerospace@luminatorusa.com | www.LuminatorAerospace.com



THE BLACK HAWK'S NEW LIFE

BY JEN BOYER

After more than three decades in the military, the Sikorsky UH-60A Black Hawk has begun a new life with civilian operators that could see it become the backbone of the heavy lift utility fleet in the U.S.



Download as wallpaper at verticalmag.com/wallpaper



A PJ Helicopters Sikorsky UH-60 Black Hawk prepares to collect water during a firefighting operation. The company is one of several to take advantage of the recent availability of Black Hawks in the civilian marketplace. **Skip Robinson Photo**

It's no secret a significant demand exists for consistently reliable aircraft with a 6,000- to 8,000-pound lifting capacity in the utility helicopter industry. The U.S. Army's Sikorsky UH-60A Black Hawk, first released for sale to the civilian market in August 2014, is poised to fill that gap as it proves its salt outside the military, making a name for itself in the world of restricted use utility operations.

According to the General Services Administration (GSA) — the U.S. government's clearinghouse for surplus goods — 112 UH-60A Black Hawk helicopters have been sold and delivered to domestic buyers since they became available in 2014. An additional 25 are sold and await delivery. This is just the beginning. The Army has suggested more than 800 of the older model Black Hawks will be retired over the next decade. Despite this number, only a little over a dozen are actively flying in civilian commercial operations today, with more poised to enter the market as they receive certification.

Originally designed for the Army, the Black Hawk's 8,000 lb.

civilian external load capability makes it the ideal solution for medium and heavy lift jobs, with the only restriction being its category. While the aircraft is designed to carry 11 people or six stretchers, Federal Aviation Administration (FAA) regulations regarding restricted category certification of military surplus platforms limit the aircraft to essential crew and cargo (internal or external) only.

Despite these limitations, the UH-60A is filling a need in a way that is exceeding operator and customer expectations.

Timberline Helicopters of Sandpoint, Idaho, operates one Black Hawk and has two additional airframes currently under refurbishment for addition to the fleet. Timberline specializes in ski lift and power line construction in addition to firefighting.

"Our primary market segment is precision heavy lift, so we try to keep an aircraft available for those customers that need to complete their projects during the summer months when most heavy lift helicopters are committed to firefighting," said Travis Storro, chief operating officer at Timberline. "We were a little concerned



Sandpoint, Idaho-based Timberline Helicopters flies one Black Hawk and is refurbishing another two to add to its fleet. The aircraft are a good fit for the company's primary market of precision heavy lift.

Ammy Jorgenson Photo

that our customers who were accustomed to the K-Max performance and capabilities might be hesitant to hire a Black Hawk, especially for high-altitude precision lift operations. However, so far the aircraft has exceeded both our customers' expectations as well as our own."

Timberline vice president Brian Jorgenson added, "We recently completed a power line project where we were setting 7,400-lb. tower components at over 5,000 feet and above 30 degrees Celsius. The aircraft handled the mission well and the customer was very happy because we were able to greatly reduce the number of hours of [S-64] Skycrane use that they required for the project."

REDUNDANCY + RELIABILITY = SAFETY

To an industry segment operating some expensive, hard-to-maintain, and often-unreliable aircraft, the biggest selling points beyond performance of the UH-60A are its reliability and redundancy. Operators accustomed to performing heavy lift operations

in older single-engine helicopters with one hydraulic system feel spoiled with the UH-60.

"The greatest aspect of the aircraft is the reliability and redundancy of the systems," said Storro. "As an operator who has always flown single-engine helicopters, it's nice to know that you've got two engines, three hydraulic sources, two generating systems, and many safety features that come with the military pedigree."

PJ Helicopters of Red Bluff, California, acquired its UH-60A Black Hawk the summer of 2015 and has since added a second to the flight line. It owns three additional UH-60 airframes with plans to potentially bring one to the line and keep the remaining two for parts.

"It's a great platform," said Justin Chaffin, director of PJ Helicopters' heavy helicopter division. "I've flown eight to 10 different aircraft platforms and this is probably the best I've ever flown. The alternate and redundant systems make it a very, very safe aircraft to fly."



Support and services for civilian Black Hawks appear to be growing as they appear in greater numbers on the market. This will then pave the way for increased use of the aircraft by operators around the country.
Skip Robinson Photo



L.A. County Fire's Air Operations unit flies the Sikorsky S-70 "Firehawk," which carries a 1,000-gallon water tanks. The aircraft is a firefighting variant of the UH-60L.
Skip Robinson Photo



The sight of a UH-60 Black Hawk in a civilian livery is set to become increasingly common in U.S. skies. **Roger E. Fink Photo**



This Black Hawk was brought to HAI Heli-Expo 2016 in Louisville, Kentucky, through the partnership between Brainerd Helicopters Inc. and Brown Helicopter under the BHI² Helicopters branding. It was a specially-equipped research and development platform to support flight test programs.

Skip Robinson Photos



The aircraft was the fourth Sikorsky UH-60A "Commercial Hawk" the partnership had completed and delivered.



It featured a pair of Robertson Fuel Systems Conformal Auxiliary Fuel System tanks, and United Test Systems data acquisition unit to gather accurate airspeed, flight control positions, airframe stresses and other related flight test parameters.

PJ Helicopters operates Bell 214, Bell UH-1, Bell 407, Bell 206L, Airbus Helicopters AS350 B3, MD 500 and MD 500N airframes in operations such as power line construction and firefighting with Bambi Buckets. However, the call for maintainable aircraft with 6,000- to 8,000-lb. lifting capability kept the company searching for options.

"The helicopter industry doesn't support the utility industry with the aircraft we need for our jobs," said Chaffin. "Their focus is the oil industry, so we're left looking for aircraft from other sources, such as surplus. Unfortunately, some of those aircraft are too expensive to maintain. When the Black Hawk came out, it was just what we needed. It has newer technology, required few modifications, and had similar operating costs to other available aircraft. It's not going to replace the Huey in my opinion because it's a different aircraft, but it fills that weight gap and is a great addition to the utility industry."

When it comes to civilian Black Hawk operations, none is more

knowledgeable than Brainerd Helicopters. The Leesburg, Florida, company purchased its first non-military version, the Sikorsky S-70, in 1995 from the Sultan of Brunei, then through a partnership with Brown Helicopter in Pensacola, Florida, acquired three more from Hong Kong's harbor patrol.

At the time, Brainerd worked with Sikorsky to receive restricted category certification of the aircraft. As a part of this acquisition and certification process, Brainerd formed Firehawk Helicopters, which has successfully operated the four S-70 aircraft under a restricted category rating in utility and fire suppression missions for years. Not surprisingly, once the UH-60A became available, it was Firehawk that received the first certification and has since added five UH-60A aircraft to their fleet.

"Being the trailblazer for this aircraft, making the investment, was a little scary to start, but we saw how great the aircraft was and we believed in its abilities," said Bart Brainerd, president of Brainerd Helicopters and Firehawk Helicopters. "We've been



Night Vision... In Stunning High Definition

SERVING FIRST RESPONDERS WORLDWIDE SINCE 1994

- AIRBORNE LAW ENFORCEMENT
- AIR MEDICAL TRANSPORT
- AIR SEARCH AND RESCUE
- AERIAL FIREFIGHTING

INTEGRATED NVG COCKPIT MODS

- OEM/FAA APPROVED AVIONICS MODS
- EDGE LIT PANELS AND OVERLAYS
- EXTERNAL LIGHTING
- EXCEPTIONAL NIGHT AND DAYLIGHT READABILITY

Approved OEM NVG Mods for...



3227 W. Eules Blvd., Eules, TX 76040 USA | Phone 817.571.0729 | Fax 817.283.5432 | www.aerodynamix.com | sales@aerodynamix.com
FAA/EASA Repair Station - C73R723N/EASA.145.6260



CRITICAL VISION TECHNOLOGY

To see, to save and protect



WORLD LEADING SEARCHLIGHTS

- Superior beam quality & efficiency
- Selectable internal multi-mission filters
- Optional dual TI/TV sensors
- Industry-best reliability



NEW GEN GYROSTABILISED CAMERAS

- Family of 200, 300 & 400mm systems
- Single & multi LRU configurations
- Leading multi-spectral sensors
- Fully exportable

trakkasystems.com

operating it safely and successfully for 20 years and it's exciting to see it come out into the market. I really think this is only the beginning."

TYPE CERTIFICATE WOES

Originally costing around \$5 million, the stripped down surplus UH-60A aircraft sells for between \$400,000 and \$800,000 depending on its state of mechanical repair. All military equipment, avionics and even some systems are removed. While some are airworthy at the time of sale, all require some level of refurbishment and maintenance, as well as full certification, before they can go to work. And the only type certification available is the prohibitive restricted category.

PJ Helicopters' Chaffin said the initial restricted category type certification was quite a process, requiring significant time, testing, paperwork and manual rewrites.

"The FAA doesn't view the UH-60A as any type of helicopter with a type certification," Chaffin said. "To them, it's a random machine with no validation to be legal. We had to do all the paperwork to show all legal parts were met; edit maintenance, flight and training manuals; and add markings and instruments. With everything the government did to the aircraft before surplus, we had to make a change. For instance, they took off the deicing equipment, so we had to remove that from the manuals. All of that added up."

The standard restricted type certification for the Black Hawk

allows for agricultural, forest and wildlife conservation and external load operations, all with only essential crew and no flights over populated areas. Operators, however, see so much more opportunity if the aircraft's full potential was allowed.

"My personal opinion is that the UH-60A would be the ultimate 'helitack' platform," said Timberline's Storro. "Because it was designed to move a lot of troops, to do rappel operations, carry external loads, and go fast, it's perfectly suited to the initial attack fire mission. However, since the aircraft is restricted from carrying passengers, the only legal way to perform these operations would be as a public aircraft under contract to a federal or state agency that was willing to assume responsibility for the oversight of the aircraft and move it out of the FAA realm. . . . I hope someone figures it out though, because you could put a lot of people on the fire much faster with a Black Hawk than with any other platform currently in the government's firefighting arsenal."

Another downside of the restricted category is the absence of safety bulletins and other safety sharing options with FAA oversight. In response to this, Brainerd has taken the lead to start an informal sharing community with other UH-60 and S-70 operators, including PJ Helicopters and Timberline.

"We may be competitors, but the market is big enough for us all," Brainerd said. "It is more important to share safety-related knowledge. You want everyone to be engaged and as safe as possible and enjoy the aircraft as much as they can. In fact, we helped with the initial training for PJ and Timberline. Working together we can maintain the aircraft's superior safety record."

Firehawk Helicopters operates the world's only commercially available Sikorsky S-70 in the world, which now operates alongside the UH-60A Black Hawk. **Skip Robinson Photo**





NEW COMPOSITE MAIN ROTOR BLADE NOW AVAILABLE FOR BELL 206B SERIES

This new Van Horn Aviation composite main rotor blade available exclusively from Aeronautical Accessories is carbon fiber constructed and has a laminar flow airfoil shape with tapered tips, reducing cabin noise. It offers weight and dimensions comparable to the standard Bell 206 main rotor blade and is FAA Authorized. To further increase operational performance, Van Horn composite Bell 206 B/L series tail rotor blades are also available from Aeronautical Accessories.

AERO-ACCESS.COM | SALES@AERO-ACCESS.COM | 1-800-251-7094



Innovation. Reliability. Performance.

Aeronautical
ACCESSORIES™
A Bell Helicopter Brand

PARTS DILEMMA

As with many surplus aircraft, Black Hawk operations are limited by reliable parts sourcing. Brown Helicopters has provided factory parts for Sikorsky aircraft for close to 40 years, helping keep Firehawk's S-70 aircraft flying. However, other sources are hard to come by.

"The worst part [of UH-60 ownership] is the infancy of the support market and the lack of spare parts for sale from reputable sources," said Timberline's Storro. "To date, most operators who are serious about buying aircraft are purchasing at least one aircraft just for spares."

Brainerd adds: "The government has not been selling parts for eight years — a move by the current administration. The only option is to buy surplus. I've seen more Black Hawks bought for parts than for operation."

Many operators, such as PJ Helicopters, solve the parts problem by purchasing one or two additional aircraft solely for their own parts sourcing. Other companies, such as Unical Aviation, are purchasing large numbers of aircraft, stripping them down, refurbishing parts, and making them available to UH-60 operators around the world.

BRIGHT FUTURE

To date, four times more UH-60As have been sold than surplus sales of the Boeing CH-47 Chinook. Despite its restricted category limitations, it has promising potential.

"This helicopter is the future of utility helicopter operations," said Storro. "Since most utility operations for heavy-lift aircraft involve only the required crew to maximize performance and payload and are conducted in remote areas where you can't get a crane or other means of lifting the payload, there is plenty of work to be had regardless of the certification basis."

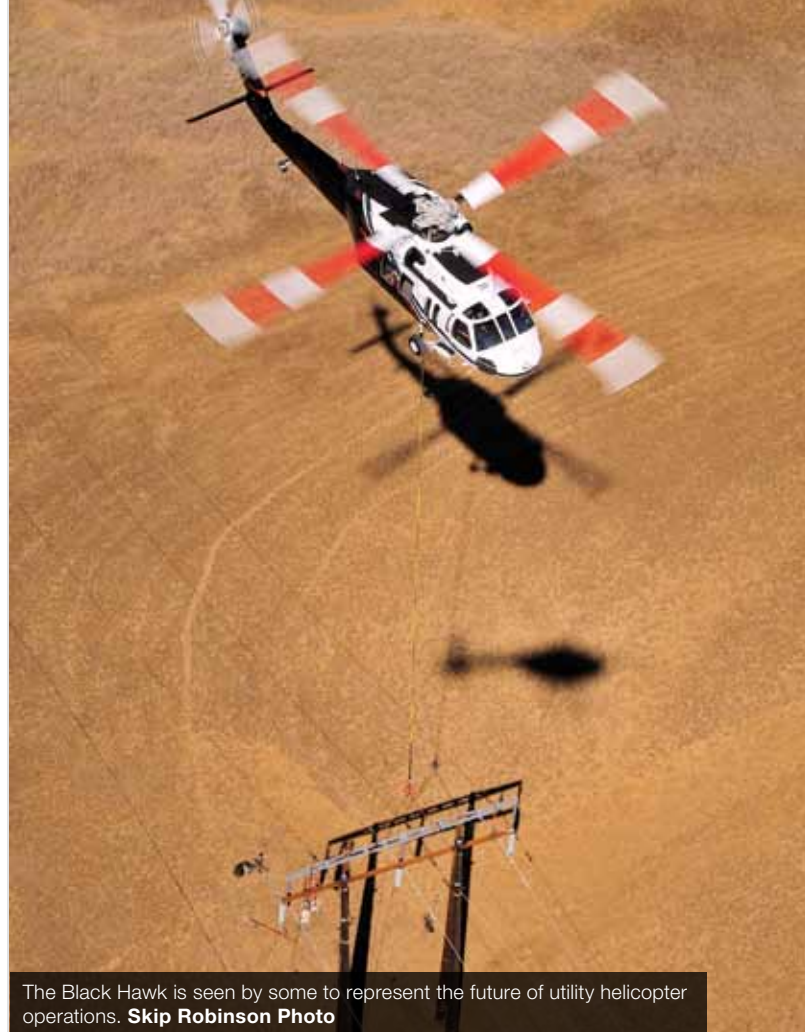

The Black Hawk is seen by some to represent the future of utility helicopter operations. **Skip Robinson Photo**



The U.S. Army has indicated that more than 800 older model Black Hawks will be retired over the next decade. According to GSA figures, 112 Black Hawks have already been sold and delivered since they became available in 2014. **Skip Robinson Photo**

Brainerd sees a future where the Black Hawk will dominate utility operations, even moving into more parapublic and public agency support.

"This has been the primary aircraft in the Army for so long, there are a large number of pilots and mechanics with considerable experience with the airframe," said Brainerd. "As police, local, and federal agencies look at aircraft options, I see the Black Hawk becoming more popular. And under those agencies' public use operations, they will be able to carry people and fly over populated areas, like Los Angeles County does with their firefighting aircraft."

Additionally, many companies have begun developing enrichments for the aircraft, such as Rogerson Kratos' modernized UH-60 cockpit and Arista Aviation's refurbished UH-60s. This new interest in offering support and enhancements for the aircraft that will assist in paving the way for increased use.



Over 40 UH-60/S-70 aircraft are operated or available for acquisition between the partnership of Brainerd and Brown. **Skip Robinson Photo**

"I may be biased, but I consider the Black Hawk the pinnacle of rotorcraft design," said Brainerd. "It is unsurpassed in the marketplace today. The commercial industry doesn't have an aircraft that exceeds it in terms of performance, safety and reliability. Every aircraft since it was released, even Sikorsky's own aircraft like the S-92, doesn't have the capability, redundancy and safety of this aircraft. It was designed to be a battlefield helicopter — fight, fly, fight — without a lot of time down for daily maintenance. Even its landing gear is a higher standard than what you find in the commercial market. All of this has made it ideal for firefighting. The Black Hawk's only Achilles Heel is that Sikorsky didn't certify it for domestic civilian operations." ❖



Jen Boyer | Long-time communications professional Jen Boyer is a 1,500-hour helicopter pilot with commercial instrument, flight instrument and instructor instrument certificates. When not flying, writing or spending time with her husband and two kids, Jen mentors current and future Whirly-Girls.



Crucial Response

Advanced displays and IFR navigation
for air medical transport.



5-inch FPCDU, UNS-1Fw FMS

THE MOUNTAIN KING

After 45 years of high performance in the most punishing conditions in the world, the Aérospatiale SA 315B Lama is slowly being retired from operators' fleets. *Vertical* took part in a special photo shoot to capture the aircraft in flight before it disappears from our skies. **Story & Photos by Skip Robinson**



With a light airframe and strong engine, the Aérospatiale SA-315B Lama started life with an advantage.



Download as wallpaper at verticalmag.com/wallpaper





Still equipped with analog gauges, the Lama shows its origins in the 1960s.

The Aérospatiale SA 315B Lama is a rare sight in U.S. skies these days — so if the opportunity to photograph one on an air-to-air shoot arises, it's hard to turn it down. In its day, the Lama's altitude performance was unmatched, and it was famed for its reliability. But once the Airbus AS350 B3 and B3e (H125) AStar entered the market, matching and then exceeding the Lama's hot and high performance, the older aircraft's fate was sealed.

Dwight Jones, owner of Mountain Air Helicopters of Los Lunas, New Mexico, flew Lamas in his fleet for 17 years. But while the Lama was still certainly capable of the tasks it was assigned, Jones found his utility customers were increasingly asking for the Airbus H125 instead. Add to this the Lama's high operating cost and the difficulty of obtaining parts in a timely manner, and Jones said it was clear its time as part of the Mountain Air fleet had come to an end. But before the company's two Lamas were sold, Jones invited *Vertical* to join him on one of his last flights in the aircraft for a special photo shoot — the results of which you can see on these pages.

With a powerful and reliable Turbomeca Artouste IIIB turboshaft engine, the Lama has always had a huge power margin.



Is Your Fleet Prepared for the Helicopter Air Ambulance FDM Mandate?



The Sky Connect™ Tracker III by Honeywell is the ideal solution for the FAA's Helicopter Air Ambulance Flight Data Monitoring mandate. The **Tracker III** is the smallest, lightest and most reliable global mission management system available, offering dual-channel simultaneous use of voice/data communication and tracking features.



MASCO Service is a Honeywell licensed and authorized dealer and service center for all of your **Sky Connect** products including the industry-leading **Tracker III**.



337-364-0789 LA
817-481-8205 TX
mascoservice.com



The Lama could sling loads of up to 2,205 pounds to places a much larger helicopter could not venture.

BIRTH OF THE LAMA

The Lama program started in the late 1960s, following a request from the Indian and Nepalese militaries for a helicopter that could operate in the extreme mountain ranges of both countries. The aircraft mated the lightweight five-seat SA 313 Aérospatiale Allouette II airframe with the dynamic components of the larger and heavier seven-seat Aérospatiale SA 316 Allouette III. The goal was extreme hot and high performance, with the ability to lift a useful load well beyond 10,000 feet. Aerospatiale engineers hoped that by combining the best from these two aircraft, they would be able to accomplish this.

On March 17, 1969, the SA 315B Lama, powered by a Turbomecca Artouste IIIB turbine engine (derated to 550 shaft-horsepower), lifted off on its maiden flight. It achieved certification on Sept. 30, 1970, and entered service in July 1971. The Lama quickly became popular around the world for high altitude mountain operations, including for oil-and-gas exploration, long line equipment placement, lift work, firefighting, and search-and-rescue.

Due to its superb hot and high performance, the SA315B is particularly suited to working in mountainous areas, and it soon proved it could lift slung loads of up to 2,205 pounds (1,000 kilograms) to places a much more powerful medium helicopter could not venture. In the extreme mountains ranges of India and South America, the helicopter could lift heavy loads and rescue people in places that were not previously possible.

Mountain View Helicopters

• 402 A Otter Bay Calgary, AB T3Z 3S6 •
• Tel: 403-286-7186 • www.mvheli.com •

Helicopter Flight Training

- Private, commercial and instructor licences available
- Recurrent and advanced training
- Night ratings
- Type ratings
- Float training
- Slingshot
- Long lining
- Approved mountain training
- In-house DFTE & DACP
- Springbank Airport offers excellent forestry mountain and control zone areas at our doorstep
- Experience with International students and foreign licence conversions
- Full and part-time courses available
- IFR Ratings
- We hire from our Graduates**

MVH
MOUNTAIN VIEW HELICOPTERS

CALEDONIAN ADVANCED PILOT TRAINING

NEED A EUROPEAN LICENCE?

We provide the modular ground study courses required to convert your ICAO professional helicopter and airplane licenses to their EASA equivalents quickly and efficiently.

At our base in Florida, you can complete your ground and flight training in one location.

CAPTONLINE.COM

CALEDONIAN ADVANCED
PILOT TRAINING

49NORTH
HELICOPTERS.COM

Commercial/Private | Instructor | Mountain | Night | Recurrent | R22, R44, EC30, BH06

Campbell River, BC • (250) 202-4899

Great Lakes Helicopter Private Career College offers the following programs:

- Conestoga College – 2 Yr. Diploma in Aviation
- General Commercial License – full or part time courses
 - Private
 - Conversions
 - Instructor
 - International
- Additional courses available

R22 – R44 – Bell 206

Introducing 3P: Pilot Proficiency Program. Call for details

FLIGHT TRAINING

Great Lakes Helicopter

Region of Waterloo (YKF) Airport, Breslau, ON N0B 1M0 • 519-648-3732
877-648-3732 • info@greatlakeshelicopter.ca • GreatLakesHelicopter.ca



The Lama proved its worth in a variety of operational sectors around the world, but proved particularly adept at flying in mountainous environments.

Dwight Jones of Mountain Air Helicopters has been flying Lamas for 17 years.



The Lama set an absolute altitude record for its class of helicopter in 1972. The record stands to this day.





Looking somewhat like a flying bug, the Lama is considered unattractive by some, but beautiful by others.

It secured its most notable high-altitude achievement on June 21, 1972, when Aérospatiale test pilot Jean Boulet took the aircraft to 40,820 feet (12,442 meters) — an absolute altitude record (for its class of helicopter) that still stands to this day. Soon after it reached its peak altitude, the engine flamed out — and Boulet brought the Lama to a unpowered landing, setting another record for the highest altitude autorotation.

Pilots loved the Lama because of its strong engine, stability in the hover, and — in the firefighting mission — the ability to lift a bucketful of water almost anywhere asked of it. For oil-and-gas support in the Colorado mountains, pilot Steve Ricks told *Vertical*: “We put a full load of fuel in it, four passengers, and their equipment — and even during the summer months we never ran out of power. Today, in comparison to an AStar, it is high maintenance, but . . . other than speed can do anything the AS350 B3e can do. The Lama was a high altitude powerhouse — we slung a lot of cargo with it and it was an amazing platform for scouting line and

reconnaissance. You could remove the doors and have a great view.”

Since entering service, the Lama has flown almost every possible mission around the world. It has flown mountain rescues throughout Europe, Asia, South America, and North America; it has completed oil-and-gas exploration support in the U.S. mountain states, proving it can lift heavy loads on the warmest days; and it has performed firefighting work throughout the U.S. from the 1970s to the present day. (During fire operations the Lama was used as a command and control platform, for personnel transport, and as a direct fire attack aircraft using a Bambi Bucket.)

But after nearly 45 years of service, the Lama is slowly being retired — and it is being left to the H125 to continue the fine high-altitude tradition the Lama established, performing a vital array of missions in the most extreme conditions in the world. ❖



We specialize in
ADVANCED HIGH ALTITUDE INSTRUCTION

Our goal is to prepare students to fly in mountainous terrain by focusing on advanced power management and flight planning, snow operations and avalanche safety and understanding weather unique to mountain environments.



(970) 259-1423
coloradohighlandhelicopters.com



NATIONAL HELICOPTERS INC.

FLIGHT TRAINING COLLEGE

- COMMERCIAL
- PRIVATE
- INSTRUCTOR
- NIGHT
- INSTRUMENT
- TURBINE
- LOGLINE
- FLOATS

TRAIN WITH THE BEST
...GET HIRED BY THE BEST

TRAINING SINCE 1985

11339 ALBION VAUGHAN RD. KLEINBURG, ON L0J 1C0
1-866-361-1100 | 905-893-2727 | WWW.NATIONALHELICOPTERS.COM

JERRY TRIMBLE HELICOPTERS
Home of the Touchdown Autorotation Contest

SPECIALIZING IN R-22 CFI TRAINING & TOUCHDOWN AUTOS
PRIMARY & INSTRUMENT INSTRUCTION
LONG LINE INSTRUCTION

Oregon • Texas • California
Cash rates -
\$200/hour solo
& \$230/hour dual



T: 503-577-6371
www.jerrytrimblehelicopters.com

jerry trimble helicopters

DID YOU KNOW?

19,676 per FAA 2016
of heli/airports in USA

40th
busiest airport: where we train

1
flight school offering plane & helicopter training



100% student job placement to date.
Proud Veteran employer.
Full touchdown training.
We train law enforcement.

EAT SLEEP FLY



EatSleepFly.com

The Magnificent Se



Len Page sits in the cockpit of the Royal Navy R-4B helicopter KK969, while his crew sit on the floats in Portland, England, sometime in 1945. **L. Page Photo**

Seven

The story of the seven Canadians who trained as helicopter pilots at the Royal Navy Helicopter School at Floyd Bennett Field during World War II.

By Bob Petite

In March 1943, the Royal Canadian Navy (RCN) decided to allow its personnel to train as pilots and observers with the Royal Navy as part of the Fleet Air Arm. At the time, the RCN had no air arm of its own, and the personnel were members of the Royal Canadian Navy Volunteer Reserve (RCNVR).

The British government was then exploring the potential for using helicopters to protect ship convoys from German submarines and had placed an order for 250 Sikorsky helicopters for the purpose. By January 1944, the British had already received three Sikorsky YR-4s. The initial helicopter training for the British pilots — who were joined by 10 RCNVR officers — was to take place at the U.S. Coast Guard (USCG) Air Station at Floyd Bennett Field, Brooklyn, New York, in 1944. The agreement was for the Canadian personnel to join the Royal Navy on loan for operational duties once the training was complete.

Lieutenant Commander E.A.H. Peat, who had soloed on the Sikorsky XR-4 back in June 1943, was chosen to command the new Royal Navy Helicopter School at Floyd Bennett Field. On June 1, 1944, the school was commissioned. The Royal Air Force delegation in Washington, D.C., turned their helicopter personnel over to the British Admiralty delegation to assist the Royal Navy in training new pilots. Student helicopter pilots came from all over the British Commonwealth.

The original plan was to train 30 helicopter pilot crews by Nov. 1, 1944. Initially, preference was given to six naval pilots with at least 500 flying hours, including operational experience. The remaining 24 naval pilot candidates were to come from Service Flying Training Schools (SFTS) in Canada. The British set up separate flight training classes, but worked side by side with the USCG in ground school training. Ten Sikorsky YR-4Bs and R-4Bs were used as training helicopters, all in British markings.

A select group of seven Canadians, who had joined the British Fleet Air Arm, trained as helicopter pilots at the Royal Navy Helicopter School between June and December 1944.

Canadians Lt J.P. Fournier, Lt E.M. Marshall, SLt K. Parker (RCNVR), and SLt W.D. Jackson (RNVR) were among those attending the first class in June. The second course saw Canadians SLt L.F. Page and Lt J.W. Stewart (RCNVR) trained. The seventh Canadian was Lt CDR. D.L. Foley, (RNVR), who was the British Naval Liaison Officer (Air) at the U.S. Naval Air Station, Norfolk, Virginia. Through his chief of staff, Foley was able to obtain permission to convert to helicopters in late November after the Royal Navy had completed its main training program at Floyd Bennett Field.

FIRST TO TAKE OFF

Fournier had joined the Royal Navy on loan from the RCN for officer training in 1940, and became interested in flying while he was in England. After obtaining his pilot license, he eventually ended up serving with operational squadrons ashore and on the aircraft carrier HMS *Indomitable* flying Fairey Albacores and Swordfish. In January 1944, he was authorized for home leave and returned to Montreal, Quebec. At the end of his leave, he was posted to an aircraft ferrying group, and piloted naval aircraft to Norfolk, Virginia and San Diego, California. After several months of this, he was told that he had been selected for helicopter training.

"I had never seen a helicopter and quickly made my way to Floyd Bennett Field where the Royal Navy training school had been set up," he later recalled. "I had the opportunity to go for a familiarization flight that day — this was my first introduction to this aviation activity."

Fournier met Marshall, Parker, and Jackson soon afterwards, and they began their training on the YR-4 in early June 1944.

"Igor Sikorsky gave us a lecture on the helicopter," said Fournier. "He was somewhat difficult to understand due to his thick accent [and] I often thought he was over one's head the way he explained the intricacies of flying helicopters."

Recalling the experience of learning in the R-4, Fournier said it was "quite underpowered and difficult to control" at first. "Autorotation practice was right to the ground," he said. "Ground resonance was critical in the R-4. We were all quite young and the element of danger flying the R-4s didn't seem to affect us. Everything was new and exciting."



An aerial view of the USCG base at Floyd Bennett Field, N.Y., in 1944. The British Royal Navy Unit is on the far right. **USCG Photo**

Following completion of the course, Fournier returned to the U.K. and test flew fixed-wing aircraft at the Fleet Air Arm's main overhaul and repair base at Donibristle, near Edinburgh, Scotland. "I did not get near a helicopter again until early 1945," he said.

Bill Jackson and Ken Parker were both at No. 31 SFTS, Kingston, Ontario, when they heard about the Royal Navy Helicopter School.

"We had just finished our advanced training on Harvards in May 1944, and when the Royal Navy were giving us our wings, they asked for volunteers," Jackson said in a later interview. "They gave us a line that they wanted to see if someone could come straight out of advanced training on fixed-wings and immediately learn how to fly helicopters. I can tell you that there was some long faces when they saw how easily we were able to fly these new machines."

After 7 hours and 30 minutes of dual training, Jackson soloed on July 3.

"The early Sikorsky R-4s had some very serious limitations," he said. "You couldn't fly above 250 feet, and on a hot day with more than five gallons of gas the R-4 wouldn't even get off the ground. We [also] couldn't fly in the rain or in winds over 15 to 20 knots."

With their training complete, Jackson and Parker went to England to fly operationally on fixed-wing aircraft. Parker was killed in December 1945 while flying a Barracuda over the North Sea.

Marshall, the fourth Canadian in the first class, had a stint in Yarmouth, Nova Scotia, at the Naval Air Gunnery School before he joined the Royal Navy Helicopter School. There, his instructor was SLt. John Jeffreys.

"We used to practice close to Rockaway Beach," he recalled years later. "One day I was flying dual with instructor Jeffreys. I had already done a couple of landings and takeoffs. Jeffreys got out to observe my flying, as many of the instructors used to do, watching the students from

the beach. As I lifted off, the right side came up first, resulting in the left wheel contacting the ground. Next thing I knew, the right side wheel touched. All I could think was, 'Gosh, this was ground resonance. Here I go.' I pulled up the R-4's stick and wobbled into the air. The helicopter began to pitch and yaw and shake. Somehow I was able to settle it down and came around to land. I could see John standing below me with his hands up in the air. I got it down and expected the worst. Jeffreys came over. He said to try it again. I lifted off with no problems after that."

Marshall said another interesting part of the course was landing and taking off from the "seasick" deck platform. "Because of the platform's movement, which simulated a rolling deck on the ocean, one always had to approach it into the wind," he said. "You had to make sure your wheels were locked when touching down. The difficulty was dropping the R-4 just when the platform was about level. On taking off and getting high enough in a hover, one had to watch that the pitching deck did not hit your tail. It was very nerve-wracking. You needed all the cushion of air that you could get in order to build up your speed and takeoff."

Shortly before the end of the course, Marshall was asked to stay on as an instructor. In addition to this, he was involved in other interesting duties, including the first night flying by the Royal Navy in R-4Bs, working with the USCG testing a rescue hoist, and flying the Sikorsky R-5 and R-6.

FINISHING THE PROGRAM

Among Marshall's first students was a fellow Canadian — Stewart — who was part of the second training program along with Page. The two had gone directly to the school from the SFTS in Kingston. "I had not requested to learn to fly helicopters," Page later recalled. "It was right out



HELICOPTERS
SAVE **LIVES**,
HELICOPTERS
SAVE **RHINOS**

Rhino Air is a charity dedicated to using helicopters with advanced thermal and night vision technologies to prevent the needless slaughter and poaching of Africa's Rhinos and Elephants.



Contact us at **1-800-553-9176**
and help put an end to poaching.

CORPORATE SUPPORTERS:

Vertical
THE PULSE OF THE HELICOPTER INDUSTRY

CHURCHILL
NAVIGATION

NIGHTFLIGHT
CONCEPTS

Rotor Zen
HELICOPTERS

GYRONIMO
FOR AVIATORS



rhinoair.org

Rhino Air is a U.S 501 (c) (3) public charity



A British Sikorsky YR-4 helicopter practices hovering near Rockaway Beach, Long Island. **John Redford Photo**

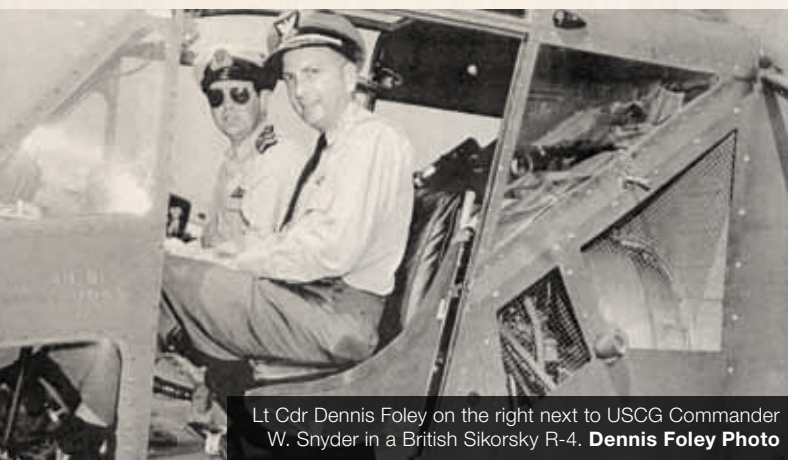

Lt Cdr Dennis Foley on the right next to USCG Commander W. Snyder in a British Sikorsky R-4. **Dennis Foley Photo**

of the blue. Why I was picked, I have no idea!"

His training began on Aug. 5 in a Sikorsky R-4B. "Most of our flying was done over a bog near the air base on 30- to 40-minute flights, as one tended to get tired from the heavy controls, said Page. "Autorotations were done each time we went up. It was quite scary at first, as you come down very fast!"

Page soloed during a five-minute flight on Aug. 14 after only five hours and 15 minutes of training. "Typical trips included the local beaches to buzz the bathers and flying alongside moving trains to wave at the passengers," he said.

The main training program for students finished on Nov. 24, 1944. The British unit at Floyd Bennett received orders to move the aircraft and instructors back to England on Jan. 1, 1945. However, this still gave Foley time to become the last Canadian trained on helicopters before the end of the war. He had been at Floyd Bennett Field on numerous occasions, seen the R-4s flying, and was able to return to the base and qualify on the aircraft before they were shipped out.

"The Royal Navy had finished their courses and were getting ready to pack up and go to the U.K.," he said. "I was fortunate that there were plenty of aircraft and instructors."

This perhaps explains his speedy conversion: his first flight was on Nov. 28, and on Dec. 2, after six hours and 30 minutes of dual training, he soloed in the R-4. He finished the course in early December.

Because he was familiar with the coastline, Foley was put in charge of arranging the transfer of the 11 R-4 helicopters to Norfolk, Virginia, for the trip on the escort carrier HMS *Thane* to England. A week before the formation flight, Foley and Peat (the school's commander) flew an R-4 down to Norfolk to become familiar with the proposed route.

Marshall arrived from Montreal to accompany the pilots and aircraft back to England. They set sail for Belfast, Northern Ireland, on Jan. 3,



This British Sikorsky R-4 was one of two left in the U.S. after the training was completed. Canada was offered them but turned them down. **Dennis Foley Photo**

1945 — but on Jan. 16, the escort carrier was struck by a torpedo. "Halfway across the Irish Sea, we were hit by the torpedo," remembered Marshall. "It knocked the stern off her and a lot of the helicopter mechanics were killed. . . . Things were hairy trying to get ashore during a snowstorm."

The carrier was towed into the Clyde estuary by a destroyer and grounded. The R-4s were then flown to Abbotsinch, Scotland. It was to be Marshall's last flight in an R-4 — he returned to Canada in May and joined a group that became the nucleus of Canada's Fleet Air Arm.

THE SEEDS OF AN INDUSTRY

Cooperation between the USCG and the Royal Navy helped to play an important part in the initial development of the military helicopter for rescue and antisubmarine patrol protection. Two British R-4Bs remained in the U.S., and were used on various trials and experimental work, including deck landings, communications, mine sweeping, and rescue and medevac operations during 1945.

R-4 deliveries had been delayed somewhat, and as a result, fewer pilots were required. The operational use of helicopters was also under review by the British military.

One of the first naval helicopter flight units was established in the Orkney Islands at Royal Naval Air Station (RNAS) Twatt. Fournier, who had been flying as a test pilot at the Fleet Air Arm repair base near Edinburgh, Scotland, relocated there after the R-4s arrived. Several had been delivered in crates, with plenty of spare parts and tools. Fournier was made officer in charge of the helicopter unit and saw to the assembly of the aircraft.

"One day I took a fleet radar officer to Stroma Island to calibrate a radar transponder," he said. "It only took a few hours to do the work. Previously, it had been a two-day trip by ship." Another successful exercise saw the helicopter assist in the calibration of the ship's radar. "One had to hover at a known height and distance of about eight miles away in sight of the ship," explained Fournier. This became a popular helicopter application.

Several months after Victory in Europe day, Fournier was repatriated back to Canada and discharged from service. Page was appointed his replacement at RNAS Twatt.

"We had three R-4Bs," said Page. "I flew them on fleet requirement work and lots of ship calibration duties. We also experimented with aerial photography. I thought we were the only ones using helicopters at the time."

Page, along with Alan Bristow, continued to fly the R-4s until May 11, 1945, when he was discharged from the Royal Navy and returned to Canada.

Back in the U.S., Foley continued flying the R-4s assigned to him at Norfolk. On May 11, 1945, he located a missing downed aircraft with

**SAVE THE
DATE!**

**Application for Exhibit Space
Available May 2016**

**Housing Open
June 2016**

**Registration Open
September 2016**

2017
HAI HELI-EXPO
BY HELICOPTER ASSOCIATION INTERNATIONAL

March 6–9 • Exhibits Open March 7–9 • Dallas
Kay Bailey Hutchinson Convention Center

heliexpo.rotor.org

Direct to Dallas





A class photo of the first helicopter training course with Canadians. Seated left to right: Lt Eric Marshall, SLt Alex Mulicrane, and Lt J.P. Fournier. Standing left to right: SLt Ken Parker, Midshipman Giles Davies, and SLt Bill Jackson.

USCG Photo

one of the R-4s and helped rescue of the pilot. For his actions, he received the Sikorsky Winged-S Air Rescue Award for airmen who were involved in life-saving missions while piloting a Sikorsky helicopter.

After the Second World War ended, Sikorsky's rapid development came to a dramatic stop. Over a period of three years and four months, the company had delivered 131 R-4s, 65 R-5s, and 219 R-6s to the U.S. Army Air Force, Navy, and Coast Guard, and the British Navy, Army and Air Force.

Foley continued flying R4s in Norfolk until December 1945, when the

Royal Navy's office was shut down. He reported back to the Royal Canadian Navy in Ottawa on Jan. 1, 1946.

The Royal Navy offered their remaining two U.S.-based Sikorsky R-4Bs to Canada, but the RCN wasn't interested in the aircraft. "The Royal Navy had said Canada could just fly them away," said Foley. "I offered to pick them up but was told by the senior air officer that the Canadians wanted jets, not bloody helicopters!" The R-4s were ultimately given to the U.S. military.

Page flew R-4s until May 1946. He recorded more than 154 hours of flight time on the venerable aircraft before leaving military service in May and returning to Canada. He eventually met up with Marshall and joined Intercity Airlines in Montreal, which was constructing Canada's first helicopter, the SG-VI.

Jackson moved to Gosport as the Royal Navy was consolidating its helicopter operations. "There we had the opportunity to further test the R-4, determining how high it could reach, and doing steep turns," he said. Jackson left the Royal Navy and returned to Canada having accumulated over 144 hours on the aircraft.

During the Second World War, seven Canadians trained on the R-4 — the Western world's first practical helicopter. Foley was the only one to stay in military service and fly helicopters with the Canadian Navy. Their pioneering efforts and initiative marked the beginning of rotorcraft development and use across Canada.



Bob Petite | An associate member of the Twirly Birds and a Gold Member of the American Helicopter Society International, Bob is a current member of the Canadian Aviation Historical Society, the American Aviation Historical Society and the Bell 47 Helicopter Association, Inc. He is the author of *The Bell 47 Helicopter Story*.

JOIN US... GET AIRBORNE WITH ALEA

AIRBORNE LAW ENFORCEMENT ASSOCIATION

advocacy airborne association aircraft
educational effective encourage
enforcement ethics expositions individual
integrity international law members mission
networking non-profit organization
professional programs promote public safety
seminars service support training values

ALEA invites you to continue your pursuit of excellence by becoming a member of our progressive Association. ALEA provides networking systems, educational seminars and product expositions that members find invaluable ... all for just \$45/year*. Join us in our mission to support, promote and advance the safe and effective utilization of aircraft by governmental agencies as a member of ALEA.

* (Individual Membership - US/Canada; International - \$65/year; Corporate \$375/year)

301.631.2406 www.alea.org



VALUES REPORT:
Gulfstream G-650 - 2012
Sold Sept. 9, 2016
Sold Value: \$63.25 Million



INTRODUCING THE NEW AIRCRAFT SOLD PRICE SOURCE.

Finally, a reliable source for data on actual business jet purchase prices. Real sold pricing from the most trusted name in business aviation data & research.



VALUES

by **JETNET**

FOR A DEMO OF VALUES, VISIT US AT THE NBAA CONVENTION,
NOVEMBER 1-3 IN ORLANDO, FLORIDA, BOOTH #3043

The World Leader in Aviation Market Intelligence
800.553.8638 +1.315.797.4420 jetnet.com

**NEW MILESTONE-PATENTS NOW GRANTED
NOW EXHIBITING A 3500HR TIME IN SERVICE RETURN UNIT**

TIRED OF COMPRESSOR CASE PLASTIC LINING FAILURE?

PROBLEM SOLVED

AvidAir's **Carbon Fiber Composite**...a whole new level of performance & durability

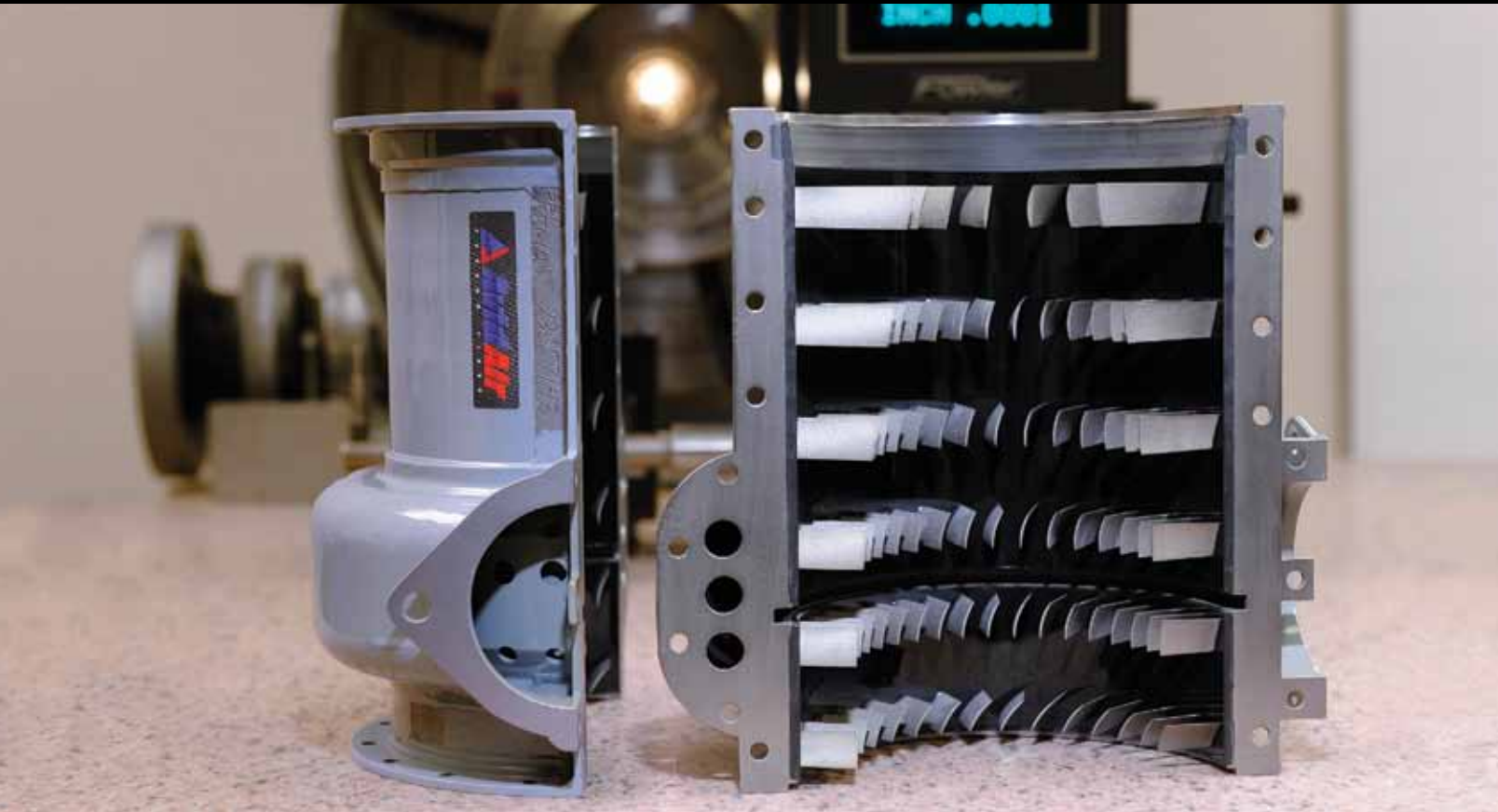

Over 2000 Carbon Fiber Composite lined compressor cases are serving customers worldwide, such as the DEA, EMS fleets, police departments and militaries operating in the harshest environments. You too can enjoy longer TBO's than ever before, guaranteed. The industry's best compressor case is backed by an industry leading 1200 hour warranty.

AvidAir International

sales@avidair.com

816.246.4527   @AvidAirInt **www.avidair.com**

 **AvidAir**
C A R B O N F I B E R

MarketPlace

YOUR #1 ROTORCRAFT RESOURCE FOR...

MRO \ PRODUCTS \ SERVICES \ SALES & LEASING \ EMPLOYMENT



Come by and see us at HAC Booth 522

Aero Design Ltd.
Helicopter Cargo Baskets and Accessories

www.aerodesign.ca

MRO

PRODUCTS

SERVICES

SALES & LEASING

EMPLOYMENT



INTER MOUNTAIN

TURBINE SERVICES, INC.

LT101 – HTS900
 Triumph Engine Control Systems
 +1 (801) 785-9898
www.intermountainturbine.com



Introducing the
LTS101 & HTS900 FIELD SERVICE KIT
 EVERYTHING YOU NEED
 WHERE YOU NEED IT

Engine Shop | AOG Support | Rental Engines | Test Cell | Spares

Honeywell Authorized Service Center
 Triumph Engine Control Systems Authorized Repair Center

FAA Repair Station | ISO Certified | EASA Approved







With our global inventory, extensive experience and universal service, we are qualified and prepared to provide you with:

- FUSELAGE AND TAILBOOM STRUCTURAL REPAIR**
- REFURBISHMENTS, EXCHANGES AND MODIFICATIONS**
- D.A.R. DESIGNEE ON-SITE**
- EXTENSIVE PARTS INVENTORY**
- MAINTENANCE**
- NON-DESTRUCTIVE TESTING AND INSPECTIONS**
- COMPLETIONS**
- COMPONENTS AND OVERHAULS**
- AVIONICS**









Van Nuys Airport, 16425 Hart St., Van Nuys, CA 91406 818-997-7667 www.RotorcraftSupport.com



Airbus Helicopters
Conversions & Upgrades

Helicopter Leasing, Lease
to Purchase, and Sales

Full Support: Avionics, Components,
Maintenance, Manufacturing,
Structures, Paint





L.E.D. XT LIGHTING STC • SALES & LEASING • REPAIR & OVERHAUL

 @Heliproducts

 /Heliproducts

 Heliproducts Industries Ltd

 /heliproducts

Transport Canada FAA AMO 83-05. EASA 145.7216

#350 - 18799 Airport Way. | Pitt Meadows Airport | Pitt Meadows | BC Canada | V3Y 2B4

P: 604-465-5008 | F: 604-608-9222 | E: info@heliproducts.com

heliproducts.com

EMPLOYMENT

MRO

PRODUCTS

SERVICES

SALES & LEASING

EMPLOYMENT

MRO

PRODUCTS

SERVICES

SALES & LEASING

EMPLOYMENT

YOUR FULL SERVICE HELICOPTER REPAIR SHOP!

General & major maintenance, repairs & modifications of Bell 206, MD 500 & AS350 series helicopters | Overhaul, repair, rental & exchange of Bell 206 & MD 500 components | Complete paint facility | Imports & Exports | Parts sales | Leasing



1020 Virginia Road, PO Box 128, Coombs, BC. V0R 1M0
 P: (250) 954-0668 | F: (250) 954-0667 | Toll-Free 1-877-954-0668
 info@aerosmithheli.com | www.aerosmithheli.com



FLYRITE

EDMONTON, AB

ACCESSORY OVERHAULS

STARTER-GENERATORS

**Overhauls
Rentals**

SAFRAN POWER (GOODRICH)
 SKURKA/APC • THALES (AUXILEC)
 BENDIX • B&C STARTERS

1-888-439-6020
 flyrite@incentre.net

BY THE BOOK!

This year I am celebrating a *20 year* milestone.

I would like to express gratitude to my customers, employees and suppliers who helped me reaching that achievement.

Helge Kirmse, *Chinook Aviation*



CHINOOK AVIATION INC.
 Specializing in Helicopter Structural Repairs



Certified fuselage fixtures for Bell 205A-1, 206 A/B/L, 212 and 412.
 Certified tailboom fixtures for Bell 205A-1, 206 A/B/L, 212, 412 and 204B.



542 Hurricane Dr., Calgary, AB, T3Z 3S8 • P 403.247.2498 • F 403.247.3740 • chinook@nucleus.com • www.chinookaviation.com



Support... where and when you need it!

PH: 760-806-3780 | FX: 760-806-3787
2580 Jason Court, Oceanside, CA 92056 | www.seasidehelicopters.com

**SEASIDE
HELICOPTERS INC.**



COMMERCIAL CHARTER SERVICE

- Bell 206, Bell 407, R44, R66, AS350, and Koala 119KE

APPROVED ROBINSON DEALER

R22s, R44s & R66s

- New & Used Helicopter Sales
- Full R22, R44 & R66 Maintenance
- Complete overhaul facility R22, R44 & R66
- RR300 dealer/parts distributor

PILOT TRAINING AVAILABLE



HELICOPTERS LTD.

250-287-4421

GARMIN. COBHAM CHELTON
FLIGHT SYSTEMS

Full Service Avionics Shop
• Rotor Wing & Fixed Wing

Gold River Base Port Alberni Base
Tel: 250-283-7616 Tel: 250-720-8915
Fax: 250-283-7555 Fax: 250-720-3641

Box 1000, Campbell River, BC V9W 6Y4 Fax: 250-287-4352
web: www.ebhelicopters.com email: info@ebhelicopters.com

Structural Composites

Airframe Repair & Manufacturing



REPAIR OF:

- Bell 206, 205, 212, & 412 panels
- AS 350 engine cowl hot band
- AS 350/355 canopies & cowls



MANUFACTURING OF:

- AS 350/355 intermediate panels

Sheet Metal & Composite Repairs to Helicopters & Fixed Wing Aircraft

P: 604-465-8048 | TC AMO# 97-03
scomp@telus.net | www.scomposites.com

HELICOPTER ACCESSORY SERVICE EAST

FAA ZS4R711M

EASA.145.6670

EXTENSIVE EXCHANGE

COMPONENTS AVAILABLE



HELICOPTER ACCESSORY SERVICE EAST
10102 AILERON AVENUE // PENSACOLA, FLORIDA 32506

BELL 206 // 407 // 212 // 214 // UH-1H | SIKORSKY S-76 // S-70 // UH-60
AIRBUS HELICOPTERS

MRO

PRODUCTS

SERVICES

SALES & LEASING

EMPLOYMENT

MRO

PRODUCTS

SERVICES

SALES & LEASING

EMPLOYMENT

ADVANCED
COMPOSITE STRUCTURES
We Fix Blades

SOUND SOLID SOLUTIONS

Airbus | Augusta Westland | Bell Helicopter | MD Helicopters | Sikorsky

WWW.ACS-COMPOSITES.COM

Winnipeg, MB | Sanford, FL | Stockton, CA

SELECT
HELICOPTER SERVICES LTD.

VISIT US AT HAC BOOTH #512
HYDRAULIC COMPONENT & CARGO HOOK OVERHAUL

AMO 92-04 | EASA.145.7268 P: 250.765.3317
E: info@selecthelicopter.com
www.selecthelicopter.com

CANWEST AEROSPACE

Aircraft Services (AMO/MRO)
Component Overhaul
Parts & Exchange
Avionics
Structures & Paint

ensuring safety & reliability

24/7 International
AOG and Field
Support Available

www.canwestaerospace.com
Hangar #10, 5225-216th Street, Langley, BC Canada V2Y 2N3 604.532.0322

NATIONAL HELICOPTERS INC.

TRANSPORT CANADA APPROVED
MAINTENANCE ORGANIZATION

BELL 430/429/412/212/206 SERIES
MD 500 SERIES | R22/R44/R66
AGUSTA | EUROCOPTER

- AVIONICS REPAIRS/INSTALLATIONS
- COMPLETE AIRCRAFT PAINTING
- COMPONENT OVERHAUL
- CUSTOM COMPLETIONS
- ENGINEERING DESIGN & APPROVALS
- NON DESTRUCTIVE TESTING
- AIRCRAFT HANGARAGE AVAILABLE
- INTERIORS

ROBINSON HELICOPTER COMPANY **sell** HELICOPTER MAINTENANCE FACILITY

YOUR COMPLETE MAINTENANCE CENTRE
PROVIDING QUALITY SERVICE YOU CAN TRUST

11339 ALBION VAUGHAN RD. KLEINBURG, ON L0J 1C0 | 1-866-361-1100 | 905-893-2727
WWW.NATIONALHELICOPTERS.COM

heliSUPPORT
New Zealand Limited

AIRBUS HELICOPTERS **SAFRAN** Turbomeca **DART** AEROSPACE APPROVED MAINTENANCE CENTER

- LEASE
- PURCHASE
- EXCHANGE

ENGINES -
GEARBOX -
HELICOPTERS -

www.helisupportnz.com

AVIALTA

HELICOPTER MAINTENANCE LTD.

- Sales & Leasing
- Field Maintenance
- Component Overhauls
- New & Reconditioned Parts





Now an authorized maintenance center for Airbus & Dart



HELI-PAINT







Avalta Helicopter Maintenance Ltd. Tel: 1-780-460-1800 • Fax: 1-780-458-7311 • phorvatis@avialta.com

IA 27018 SH 633 • Villeneuve Airport Sturgeon County, AB T8T 0E3 www.avialta.com

BUY OR RENT

<p>The World's</p> <ul style="list-style-type: none"> • smallest package • lightest weight • least expensive <p>New!!! FAA TSO Approved Life Rafts</p> <p>Emergency Liferaft</p> <p>Call Survival Products, the manufacturer for customer/distributor/service information.</p> <p>Made in USA</p>	<table border="0"> <tr> <td>4-6 Man</td> <td>9-13 Man</td> </tr> <tr> <td>4" x12" x14"</td> <td>5" x12" x14"</td> </tr> <tr> <td>12lbs</td> <td>18lbs</td> </tr> <tr> <td>\$1510</td> <td>\$1960</td> </tr> </table> <p>TSO'd and Non TSO'd</p>	4-6 Man	9-13 Man	4" x12" x14"	5" x12" x14"	12lbs	18lbs	\$1510	\$1960	
4-6 Man	9-13 Man									
4" x12" x14"	5" x12" x14"									
12lbs	18lbs									
\$1510	\$1960									

SURVIVAL PRODUCTS INC

Phone: 954-966-7329 • Fax: 954-966-3584
5614 S.W. 25 Street • Hollywood, FL 33023
www.survivalproductsinc.com • sales@survivalproductsinc.com

SAFETY • EFFICIENCY • SERVICE



Specializing in Bell Helicopters: 204, 205, 206, 212, 407 & 427

- Dynamic Component Overhaul • Exchange & Rental Program
- Part Sales • Bell Approved Blue Coat Repairs



Approved Bell Helicopter Textron Customer Service Facility

"Our Commitment, Your Advantage"

PROUDLY SINCE 1978

Box 190, 3010 Selwyn Rd., Valemount, BC V0E 2Z0 T: (250) 566-4401 F: (250) 566-4333 | www.yhl.ca

BROWN HELICOPTER INC

PENSACOLA, FLORIDA • FERGUSON AIRPORT 82J

Serving the Industry Since 1978

Huge inventory of Sikorsky and Bell parts as well as those hard to find parts.

We ensure a rapid response to all orders and inquiries to keep you in the air.

10100 Aileron Ave Pensacola, Florida 32506 | P: 850-455-0971 | F: 850-456-8231 | E: sales@brownhelicopter.com

MRO

PRODUCTS

SERVICES

SALES & LEASING

EMPLOYMENT



HELIROLLDRUM

TOUGH TANKS - COLLAPSE COMPACT

DOUBLE REVENUE FLIGHTS & NO EMPTY RUNS! DEFUEL & LIFT MAX. – THEN REFUEL FOR HOME RUN.



AUSTRALIAN MADE

WWW.TURTLEPAC.COM | EMAIL: TURTLEPAC@YAHOO.COM.AU

Barfield Solutions

Make your task easier and saves time!

New Inlet Barrier Filter (IBF) : functional test application within our DPS1000 & 1811NG Pitot Static Testers with Wi-Fi Connectivity



IBF Bypass Major Components

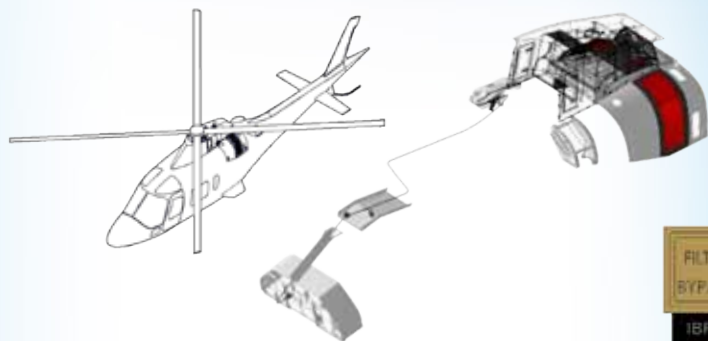

COCKPIT INDICATOR SWITCH



NAV-AIDS LTD
PITOT STATIC
ADAPTER KITS



DPS1000



1811NG

 **BARFIELD**
www.barfieldinc.com

Portable Power!

Introducing AERO Specialties new line of portable aircraft starting and continuous power units! These affordable units are powerful, durable and dependable.



+1 208-378-9888 | www.aerospecialties.com



MRO

PRODUCTS

SERVICES

SALES & LEASING

EMPLOYMENT

We speak your global aviation language...

AOG

URGENT

**Dauphin parts
in stock**



alpine.aero
air support

MRO

PRODUCTS

SERVICES

SALES & LEASING

EMPLOYMENT



HELI
TOW CART
Efficient Solutions



Quality Accessories

Helitowcart

Powerful Carriers & Tow Carts



New!

S92 on Landing Net
More Power
More Traction



Lévis, Canada 418.561.4512

NOW AVAILABLE
AT **AD-S&CO B.V.**, ALPHEN AAN DEN RIJN, NETHERLANDS

www.adsco.nl | info@adsco.nl



Visit us at
Helitech 2016
Booth #12B70

Contact us today and let us help you change
the way you move your helicopter.
ALL OVER THE WORLD.



**WIRELESS REMOTE
CONTROL LANDING DOLLY**

www.heliwagon.com | (877) 435-4946 | brad@heliwagon.com



HELICOPTER PARTS SALES
Check Out our Huge Inventory!
Over One Million Items!

We have a large inventory of quality parts from
reputable sources, for outright sale and exchange.

ACCESSORIES • COMPONENTS • INSTRUMENTS

Airbus Helicopter, Bell Helicopter, MDHC, Schweizer,
Sikorsky, Lycoming, Rolls Royce, Turbomeca

Check out our website!

WE BUY:

- Light and medium turbine helicopters
- Parts, components and inventories
- Distressed and run-out airframes



Toll Free 800-585-7004 USA & Canada Only.

TEL: USA 1+608-756-3632 • FAX: USA 1+608-756-2606

email: info@tradewindinternational.com



www.tradewindinternational.com



27 YEARS! Helicopter Ground Handling
Chopper Spotter
Still a better idea

J.B. Knowles, Inc. | Blue River, WI 53518
Ph: 1 608 537-2049 | Fax: 1 608 537-2043
info@chopperspotter.com

www.ChopperSpotter.com

PARTS AND COMPONENTS



www.ex-changeparts.com **eX-Change Parts AB**

Ex-Change Parts AB · Holländargatan 22 · 113 59 STOCKHOLM · SWEDEN
info@ex-changeparts.com · ph: +46 8 5454 9897 · fax: +46 8 5511 4755

WE SUPPORT EUROCOPTER, SIKORSKY, BELL, MD AND SCHWEIZER

MACHIDA

Borescopes

ENGINE APPROVED KITS

New DPU-7-7070 HD Video Recording
HD Video Recording | Stunning Images | Helicopter Kits



1-800-431-5420 // 1-845-365-0600
info@machidascope.com

machidascope.com

MRO

PRODUCTS

SERVICES

SALES & LEASING

EMPLOYMENT



BELL FUEL CELLS

The ultimate source for all of your Bell helicopter replacement Fuel Cells.



1-800-647-6148
www.ffcfuelcells.com



MRO

PRODUCTS

SERVICES

SALES & LEASING

EMPLOYMENT

HELIPORTER®



Paravion®
Technology Inc.
www.paravion.com

30 Years of Providing Safe
Affordable Ground Handling

AVIATION TOOLING & GROUND SUPPORT EQUIPMENT

SAI Szabo
Aviation
International



1-866-221-9473
szabosales@telus.net
www.szaboaviation.com

ONLINE AVIATION THEORY



LOOKING TO LEARN HELICOPTER OR AIRPLANE THEORY?

NOW YOU CAN LEARN
IN THE COMFORT OF
YOUR OWN HOME.

For more information,
please visit our websites

www.OnlineAviationTheory.com
www.Helicopter-Book.com

SWITLIK
SURVIVAL PRODUCTS



Air Crew Life Vests
Anti-Exposure Suits
Life Rafts



See our
All **NEW**
TSO-C70a
Life Raft!

Professional Survival Equipment for Serious Aviators.
Family Owned & American Made Since 1920.



www.**SWITLIK**.com

Visit our booths at:
Helitech & NBAA

DANGEROUS GOODS TRAINING

Web-based training for TDG by
Air for Rotorcraft & Fixed-Wing
Operations

- TDGR/IATA/ICAO Regulations
- CARS 702 & 703 Operations
- Shipping, Acceptance, Air Crew, Passenger Handling, Stores, Refueling, WHMIS and others
- Initial and Recurrent Training

Each course comes with an online
exam and immediate grading.

See our website for more
information: www.solocks.com

Solocks.com Training Inc.
Toll Free: 1-877-977-8339
sales@solocks.com | www.solocks.com

THE PROFESSIONAL AIRCRAFT MOVERS

NOW WITH
**THREE SPECIALIZED COVERED TRAILERS
FIXED & ROTARY WING**



Driven by our Customers' Success

**CONTACT US TODAY &
START SAVING MONEY!**

www.calgarygooseneck.com
403.266.2468 | 406.450.0170
doug@calgarygooseneck.com



MRO

PRODUCTS

SERVICES

SALES & LEASING

EMPLOYMENT



ELECTRICAL & AVIONICS SYSTEMS SUPPORT

SALES & INSTALLATION



SERVICE & SUPPORT



AIRFRAME REWIRE



AMO# 90-04

AUTHORIZED DEALERSHIPS

TECHNISONIC **Honeywell** ASPEN AVIONICS **BendixKing** GARMIN **COBHAM** **AEM**

SALES@AERONAV.CA | WWW.AERONAV.CA

**GRAHAM AVIATION
CONSULTING & PILOTAGE**

*"Safety Through Action...
Success Through Commitment"*



- Aircraft Sales
- Aircraft Leasing
- 3rd Party Safety Audits
- 702/703 Certification
- COM Development
- PVI / CAP Review
- Flight Training
- Dangerous Goods

www.grahamaviationconsulting.com

VERTICAL HAS AN ONLINE CAREERS PAGE

DID YOU KNOW IT'S THE FASTEST AND EASIEST WAY TO
FIND YOUR NEXT CAREER IN THE HELICOPTER INDUSTRY.

WWW.VERTICALMAG.COM/CAREERS

CONNECTING EMPLOYERS AND JOB SEEKERS
FOR MORE INFORMATION, CONTACT LEANNE WILLIS
866.834.1114 | LEANNE@MHMPUB.COM

MRO

PRODUCTS

SERVICES

SALES & LEASING

EMPLOYMENT

FOR SALE

New Simplex 510 Aerial Cleaning System

for AS350 and AS355 Series Helicopters



The **Simplex 510 aerial cleaning system** produces a high pressure spray stream to remove residue and ice from electrical towers and wind turbine blades



Brand new kit in its box, never been used, for a fraction of the price.



Fred Carrier • 418-914-5600

fcARRIER@helicarrier.com • www.helicARRIER.com

D.F. CAPITAL LTD.

AS350 B2/FX2/SD2 LEASES

206L1/C30P FOR SALE / LEASE

Don Farkas • 250-507-9668
dfarkas@shaw.ca

Denis Robitaille • 450-750-6249
denis.helico@sympatico.ca



SKYE AVIONICS LTD.

HONESTY DEDICATION QUALITY

SALES & SERVICE AIRFRAME RE-WIRING AVIONICS MODIFICATIONS

- Helmets •
- RVSM Testing •
- Airframe Rewiring •
- Avionics Packages •
- Bell 407/MD500 STCs •
- Drop Cord Manufacturer •
- ADS-B Sales/Installation •



BELL // AIRBUS HELICOPTERS
MD // ROBINSON // SIKORSKY

10% discount on an avionics package with code **SKYE202**

AVIATION FUEL TRUCKS FOR SALE



Heli-lift International Inc.

"Proudly calling Saskatchewan home since 1954"

These trucks are road legal and airport capable with fresh road safeties, prices starting at **\$39,500 USD** as currently configured.

- Remtec 18,000 litre (4760 US gallons) aluminum MC306 tank
- Tank has dual hose reel set up with over wing and under wing fuelling capability
- Scully over-fill sensors with bottom loading makes this unit able to load off the rack
- International power unit
- Tank sump drain
- Aviation fifth generation capable filtration system
- Cummins NTC or DT466 power
- Allison automatic transmission
- 16000 lb. front axle
- 46000 lb. rear tandem axles
- Michelin rubber in excellent condition



www.helilift.ca

Hangar 2 Airport, PO Box 1971 | Yorkton, SK S3N 3X3 Canada | P: 306-783-5438 | F: 306-782-3590 | info@helilift.ca

VERTICALMAG.COM

The **CLOCK** is **TICKING**



The **December/January issue** will be here before you know it!

Deadline:

Nov. 18, 2016

Contact
Carla McKay:
carla@mhmpub.com
519.748.1591

Vertical
THE PULSE OF THE HELICOPTER INDUSTRY

We are currently hiring for the following positions:

Pool Pilot

- Minimum 1500 hours total must meet Conrail requirements (which is 250 hours turbine time, 1500 total time, 50 hour time on type: BH06/BH04/AS350).

Engineers & Apprentices

- Time or experience on the following types: BH04/BH06/AS350

All applicants must possess excellent customer service skills along with organizational and communication skills and the ability to work independently and within a team environment.

Please apply in confidence, by email only, to:

Elton Ceh, Chief Pilot, ecch@deltahelicopters.com for Pilot positions.

Scott Coutts, scoutts@deltahelicopters.com for Engineers and Apprentices positions.

Only applicants chosen for interviews will be contacted.



DELTA
Helicopters Ltd.

www.deltahelicopters.com



- Pilots needed for full time employment at our Fort Nelson, BC base of operations.
 - Experience Required: Min.1000Hrs PIC endorsed on type considered an asset.
 - Bell 206, Bell 205, AStar 350BA and Daughin 366N1.
- Accommodation is supplied. Relocation costs negotiable after probationary period is completed.**

QWEST
HELICOPTERS

Apply by email including references to qwest@northwestel.net

MRO

PRODUCTS

SERVICES

SALES & LEASING

EMPLOYMENT



MANUFACTURING CHANGE

VIH AEROSPACE HAS BEEN A WELL-KNOWN MRO SERVICE PROVIDER FOR MORE THAN A DECADE. NOW IT'S SHOWCASING ITS VERSATILITY AS A MANUFACTURING, MAINTENANCE, REPAIR AND OVERHAUL (MMRO) COMPANY.

BY SARAH GRANDY | PHOTOS BY HEATH MOFFATT

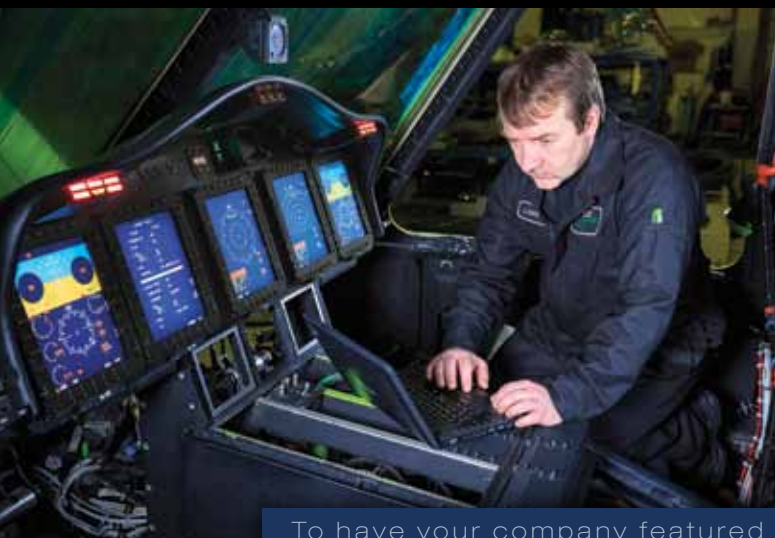

To have your company featured in **INSIGHT Magazine**, contact:

Frank Sargeant: frank@mhmpub.com | 519.748.1591

VIH Aerospace (VIHA) has been a well-known provider of helicopter and fixed-wing maintenance, repair and overhaul (MRO) services since 2004, offering a range of services including dynamic component repair and overhaul, full service avionics, mobile repair teams, structural repair and paint, engineering and supplemental type certificate (STC) development and integration services.

"Our ability to provide high quality products, services and innovations, quickly and efficiently is what separates us from other companies," said Dave McGrath, director of marketing, business development and sales.

But as the company continues to grow, it is shifting gears to become recognized as a manufacturing, maintenance, repair and overhaul (MMRO) company in the international aviation market.

"By and large, we are pushing our MMRO capabilities and our key services differentiators, as well as aggressively promoting our supplemental type certificates that we can integrate in the various Bell, Sikorsky, and Airbus products," said McGrath. "We have become more versatile internally, by partnering with other organizations to offer a more comprehensive suite of services.

"We are moving much more into the third party global MMRO market, and I keep using the term MMRO, because one of the directions that we've taken in 2015 — which is carrying through — is our focus on manufacturing," said McGrath. "So that's why we're now calling ourselves an MMRO, and it goes beyond standard helicopter MRO and manufacturing of our STC kits. One of the growth initiatives that we've undertaken in 2015 is third party manufacturing across the aerospace sector."

VIHA has the capability to manufacture many parts in-house, but also utilizes a select group of vendors to ensure capacity requirements and manufacture of certain larger parts.

"Some of the larger parts we have manufactured measure in at about 15 feet," said Arne Arneson, general manager for VIHA. "We have our preferred vendors that we use for some of the parts; however, VIHA performs the final inspections to ensure quality, dimensions and fit."

"One of the key things that we do when we outsource is manage the vendor. We manage the final quality inspection," said McGrath. "When anything comes out the door it has the VIHA stamp on it. Our quality and inspection team ensures every individual item passes a detailed inspection. This is one of the things that puts us

“One of the growth initiatives that we've undertaken in 2015 is third party manufacturing across the aerospace sector.”

— Dave McGrath, director of marketing, business development and sales

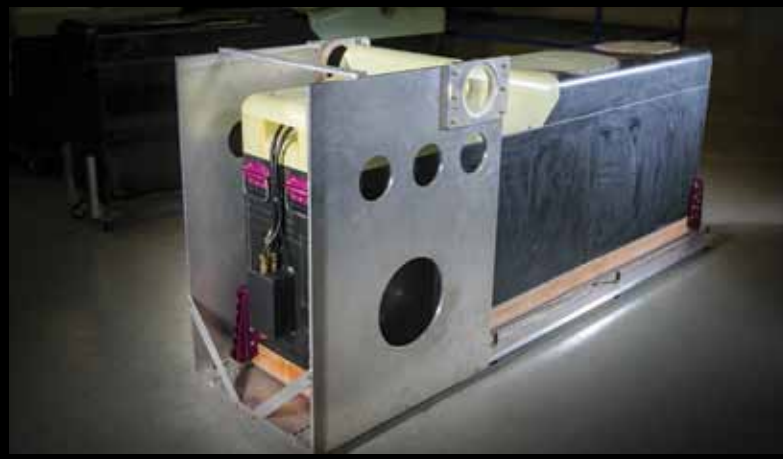

ahead of the curve."

VIHA currently manufactures a diverse range of products, from aircraft and kit piece parts to the recently certified Boost human external cargo system, and its highly successful auxiliary fuel tank found on the Sikorsky S-92.

The company has more than 60 STCs, most of which are found on Bell and Sikorsky products.

More recently, VIHA earned both Federal Aviation Administration and Transport Canada STCs for the MCP01 master caution panel found on the Bell 212. The company partnered with AEM Corporation on the development of the MCP01, which is an aftermarket replacement master caution panel, of the original equipment used on the 212.

"The MCP01 is a one-of-a-kind installation. The new panel provides a number of enhancements that positively impact aircraft safety and reliability," said Arneson. "The current 212 master caution panel is wholly based on 1960s-era design and technology; and this fact consistently results in issues of reliability and even failure that most often results in extended repair or complete replacement of difficult to procure replacement panels. This ultimately results in aircraft downtime and loss of revenue for the operator."

VIHA's avionics team is well known for its high quality service with years of experience repairing and maintaining avionics systems, including communications, radar and navigation systems, as well as performing system upgrades and modifications to meet evolving operational requirements.

"We have some of the best avionics people in the business," said McGrath. "I'd stack them against anybody as far as putting together avionics, FLIR and NVG [night vision goggle] systems. There's not a lot we couldn't tackle."

VIHA also has a number of STCs for the S-92, like the auxiliary fuel tank system, followed by various bubble windows including vertical reference windows, NVG and FLIR systems, as well as search-and-

rescue-related kits.

VIHA is planning a new, larger facility for 2016 in order to accommodate expanded services ranging from maintenance to manufacturing, production, component shop expansion, and more.

"We're going to need that space for some of the things that are already rolling out, but are going to definitely hit full stride in 2016," said McGrath.

Currently employing 45 people, 40 percent of VIHA is dedicated to manufacturing parts, while the other 60 percent is combined for component overhaul, hangar maintenance, paint and system upgrades, and STC programs.

VIHA is a Bell customer service facility that works on all Bell light and medium helicopters. But it also specializes on the Sikorsky S-61 and S-92, and is now also providing services on the Airbus Helicopters AS350/H125 and EC130/H130.

VIHA has the ability to install any certified kit on an aircraft or helicopter, regardless of whether it's a VIHA-designed product or developed by another vendor. VIHA has experience on the following models:

- Bell 205, 206 series, 212, 222, 230 and 407;
- Sikorsky S-61, S-76, S-92;
- Airbus Helicopters EC120, EC130, EC135, AS350, AS355;
- Kamov Ka-32;
- Robinson R22;
- Bombardier CL-604 Challenger; and
- Hawker Beechcraft 800A.

"We're definitely getting recognized globally now," said McGrath. "Quite frankly, the quality of our product speaks for itself and the word is getting around." ✈



www.vih.com
(250) 655-6821

The Giant Anthill

By Mike Muench

"Sir, I don't think a Huey can do that," I informed the pilot. "Well, I guess we'll find out," I heard through the intercom. It wasn't exactly the answer I was hoping for, but then, it wasn't my call. If he thinks a Huey can...

Well, before I get too deep into this, I should give you a little background. I had joined the Army to fly helicopters, so right after basic training, I asked the top sergeant for an application for flight school.

"Flight school? You're barely 17 and what, maybe 125 pounds soaking wet?"

Well, actually 120, but who's counting? "Look, you have to be 19 to get into Army flight school," I heard the sergeant say. I wondered why the recruiter hadn't brought this up before I signed on the dotted line...

"I've got you down for helicopter mechanic school when you leave here," the sergeant informed me. "Your recruiter must have figured that will give you a good foundation for when you apply for flight school in a couple of years."

Long story short, I finished helicopter maintenance school and volunteered as a door gunner aboard a Huey gunship in a land far, far away.

"You know that volunteering for this duty means that you accept the possibility that you'll be volunteering for suicide missions, right?" our platoon leader said. Suicide *missions*? Isn't that sort of an oxymoron?

I mean just how many suicide missions can one expect to participate in?

"A suicide mission is one where you have less than a 50 percent chance of returning... you know... alive," the platoon leader informed me. "Still interested?"

"Well... I guess," I heard myself mumble. This felt like I was applying for a job as a hero, when that was not who I was at all. Not a coward — but certainly no hero.

Three hundred feet over the jungles of South Vietnam, and we were being shot at. So what else was new? Well, I'd never been shot at by an elephant before. Actually, the enemy was seeking cover under the elephant, and firing at us when they thought they could get away with it. The pilot was asking — no, ordering — me to euthanize the pachyderm.

"They use them to carry arms and ammo. Do it!" he said.

"I'll shoot it! Just turn this ship around," I heard the crew chief say. A real tough guy. A legend-in-his-own-mind sort of guy. The crew chief manned the machine gun on the left side of the helicopter, opposite the gunner (me) on the right.

I started shooting at what I could make out of the enemy, and to my surprise the elephant took off into the jungle leaving its masters behind. I never thought something that big could move that fast. Well, when the pilot banked hard, mister hotshot on my

left — without his seatbelt on — almost fell out of the helicopter. Yeah, the Army needs a few more like him. On the ground.

The UH-1B is a great machine — equivalent to the civilian Bell 204. I've seen it take a licking and keep on kicking. One night, our ship followed another Huey making a noble attempt to land with the hydraulics shot out. It took both pilots on the controls. I can still see the sparks flying off the skids on the running landing at the closest airfield... What a show!

Alright, back to the maneuver that our pilot was thinking about trying to get our UH-1B gunship to perform. Picture a giant anthill: basically a big foxhole with a huge mound of dirt around it. Inside the foxhole was a 50-caliber machine gun. The pilot wanted to race up to the mound, pull into a cyclic vertical climb, nose the Huey over into a vertical dive, fire rockets into the target — and then try pulling out of the dive at the last second. I envisioned mast bumping with the tail boom being severed by the rotor blades. I know I agreed to volunteer for suicide missions, but geez, not one where your pilot tries to kill you.

The crew chief and I saw eye to eye on very little, but that this was an insane idea, we agreed completely. And so began the initial low altitude run toward the giant anthill. I figured that if I survived the inevitable crash, I would need a fresh barrel on my machine gun, because things were going to get pretty busy, pretty fast. I snatched at a spare barrel on the seat next to me, but felt it slip out of my hand as I picked it up. The sound that a machine gun barrel makes when dropped on the metal floor of a helicopter can only be described as very similar to a 50-caliber steel-jacketed round slamming into the airframe structure. You not only hear it, but you feel it with every fiber of your being. The pilot, copilot and crew chief nearly jumped out of their respective skins. The pilot was so shook up that he missed the cyclic pull-up point. As we blew past the foxhole, a call came through to suppress some ground fire nearby. Our pilot wisely called the coordinates in to the fighter bombers circling overhead to take care of the anthill — and I lived to fly another day. I passed on Army flight school and got out when I turned 20. I couldn't buy a beer for another year — and I never looked at an anthill in the same way again.



Chris Rohrmoser Illustration





INTERNATIONAL
AEROSPACE & DEFENSE

aftermarket support

YOU CAN TRUST

- > MRO
- > DISTRIBUTION
- > LOGISTICS
- > SUPPORT

M International has the tools for you to succeed, take a look at the various areas in which we can assist you and you will see

M International is the premier choice as a highly-qualified partner for customer focused aftermarket solutions.



703.448.4400

www.minternational.net





© 2016 BELL HELICOPTER TEXTRON INC.

WHEN MINUTES COUNT, RELY ON SUPERIOR PERFORMANCE

When minutes count, we know you need the best resources available to provide quality care. At Bell Helicopter, we understand and share your dedication and commitment, which is why the Bell 429 is ready to serve your operation by offering faster en-route times and cabin flexibility to meet your needs. When the situation is critical, depend on the Bell 429 for optimal care.

BELLHELICOPTER.COM |     

On a Mission.

Bell Helicopter[®]
A Textron Company